

MHI

DATA BOOK

VRF INVERTER MULTI-SYSTEM AIR-CONDITIONERS

KXZ Outdoor units

Hi-COP series

- Single use (Used also for combination)
FDC224KXZXE1, 280KXZXE1, 335KXZXE1
- Combination use
FDC450KXZXE1, 500KXZXE1, 560KXZXE1, 615KXZXE1, 670KXZXE1, 735KXZXE1, 800KXZXE1,
850KXZXE1, 900KXZXE1, 950KXZXE1, 1000KXZXE1

· Note:
(1) Regarding the indoor unit series, refer to the No.'14·KX-DB-206.

PREFACE

Combination table for KX4, KX6 and KXZXE1 series

Category	Outdoor unit		Connectable remote control		Indoor unit							
					Same series	Same series	Mixed series	Mixed series	Mixed series	Same or Mixed series	Mixed series	Same series
			3-wire type	RC-E1	KXE4	KXE4(A) KXE4A	KXE4A	KXE4A	KXE4A			
			3-wire type	RC-E1R			KXE4R KXE4BR KXE5R	KXE4R KXE4BR KXE5R		KXE4R KXE4BR KXE5R	KXE4R KXE4BR KXE5R	
			2-wire type	RC-E3 RC-E4 RC-E5 RC-EX1A				KXE6 KXE6A KXE6B KXE6D KXE6F	KXE6 KXE6A KXE6B KXE6D KXE6F		KXE6 KXE6A KXE6B KXE6D KXE6F	KXE6 KXE6A KXE6B KXE6D KXE6F
Heat pump (2-pipe) systems	FDCA-HKXE4	5HP			YES[D]	YES[D]	NO	NO	NO	NO	NO	NO
	FDCA-HKXE4	8-48HP			NO	YES[D]	NO	NO	NO	NO	NO	NO
	FDCA-HKXE4A FDCA-HKXE4R	5HP 5.6HP			NO	YES[D]	YES[D] ^{*1}	NO	NO	YES[D] ^{*1}	NO	NO
	FDCA-HKXE4A FDCA-HKXE4R FDCA-HKXE4BR FDCA-HKXE4D	8-48HP 8-48HP 8-48HP 8-48HP			NO	YES[D]	YES[D]	YES[D]	YES[D]	YES[D]	YES[D]	YES[D]
	FDC-KXE6	4,5,6HP			NO	NO	NO	NO	NO	NO	NO	YES[B] ^{*6}
	FDC-KXE6	8-48HP			NO	NO	NO	NO	NO	YES[C]	YES[C]	YES[B]
	FDC-KXZXE1	8-36HP			NO	NO	NO	NO	NO	NO	NO	YES[A]

Note (1) YES: Connectable (See following table in detail), NO: Not connectable

*1 Except FDKA71KXE5R

	Outdoor unit	Connected indoor unit		Dip switch setting of outdoor unit KXZE1/KXE6	Superlink protocol	Limitation
		Same series	Mixed series			
YES[A] ^{*2}	KXZXE1	KXE6		II (New)	New (for KXZXE1/KXE6)	New (for KXZXE1/KXE6)
YES[B] ^{*2}	KXE6	KXE6		II (New)	New (for KXZXE1/KXE6)	New (for KXZXE1/KXE6)
YES[C]	KXE6	KXE4 series	KXE6 & KXE4 series	I (Previous)	Previous (for KXE4)	Previous (for KXE4)
YES[D]	KXE4 series	KXE4 series	KXE4 series		Previous (for KXE4)	Previous (for KXE4)

*2 If outdoor unit system (YES [A] or YES [B]) is connected to other outdoor unit systems (YES [C] and/or YES [D]) in one Superlink network, the dip switch of outdoor unit KXZXE1 (YES [A]) or KXE6 of (YES [B]) should be set from II(New) to I (Previous). In this case the Superlink protocol and limitation of outdoor unit system (YES [A] or YES [B]) are switched to Previous (for KX4).

(2) Combination with new Central control, PC windows central control and BMS interface unit

		Central control, PC windows central control and BMS interface unit					
		SC-SL1N-E	SC-SL2NA-E	SC-SL4-AE/BE	SC-WGWNB-A/B	SC-LGWNA-A	SC-BGWNA-A/B
YES[A] & YES[B]	Connectable I/U	16	64	128 (128x1)	128 (64x2)*3	96 (48x2)	128 (64x2)*3
	Superlink protocol	New	New	New	New	New	New
	Connectable network	1	1	1	2	2	2
YES[C] & YES[D]	Connectable I/U	16	48	144 (48x3)	96 *4 (48x2)	96 *4 (48x2)	96 *4 (48x2)
	Superlink *5 protocol	Previous	Previous	Previous	Previous	Previous	Previous
	Connectable network	1	1	3	2	2	2

*3 Maximum number of AC Cell is limited up to 96.

In case the number of connected indoor units are more than 96, some AC Cells should hold 2 or more indoor units.

*4 In case of other Central control like SC-SLxN-E is connected in the same network, the connectable indoor unit is limited up to 64(32x2).

*5 In case of previous Superlink protocol, the Superlink mode of new central control should be set "Previous".

*6 In case of (YES[A] or YES[B]), previous central control is available to use. But the limitation of connectable indoor unit and so on is complied with the rule of previous Superlink.

CONTENTS

1. GENERAL INFORMATION	1
1.1 Specific features.....	1
1.2 How to read the model name	1
1.3 Table of models	2
1.4 Outdoor units combination table	3
2. OUTDOOR UNIT	4
2.1 Specifications.....	4
2.2 Exterior dimensions.....	6
2.3 Electrical wiring	8
2.4 Noise level.....	10
3. RANGE OF USAGE & LIMITATIONS	11
4. PIPING SYSTEM	18
5. SELECTION CHART.....	20
6. WARNINGS ON REFRIGERANT LEAKAGE	35

1. GENERAL INFORMATION

1.1 Specific features

Connectable indoor capacity

Capacity from 80% to 200% or 160% is possible.

Model \ Item	Number of connectable units	Connectable capacity
FDC224KXZXE1	1 to 29	180 — 448
FDC280KXZXE1	1 to 37	224 — 560
FDC335KXZXE1	1 to 44	268 — 670
FDC450KXZXE1	2 to 60	360 — 900
FDC500KXZXE1	2 to 53	400 — 800
FDC560KXZXE1	2 to 59	448 — 896
FDC615KXZXE1	2 to 65	492 — 984
FDC670KXZXE1	2 to 71	536 — 1072
FDC735KXZXE1	3 to 78	588 — 1176
FDC800KXZXE1	3 to 80	640 — 1280
FDC850KXZXE1	3 to 80	680 — 1360
FDC900KXZXE1	3 to 80	720 — 1440
FDC950KXZXE1	3 to 80	760 — 1520
FDC1000KXZXE1	3 to 80	800 — 1600

Note

For outdoor unit, EN61000-3-2 and EN61000-3-12 are not applicable as consent by the utility company or notification to the utility company is given before usage.

1.2 How to read the model name

(1) Outdoor unit

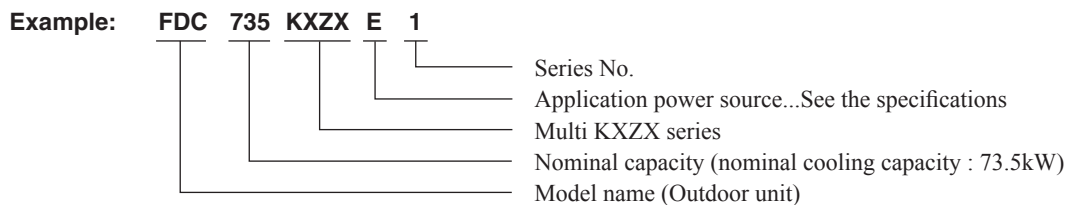

(2) Indoor unit

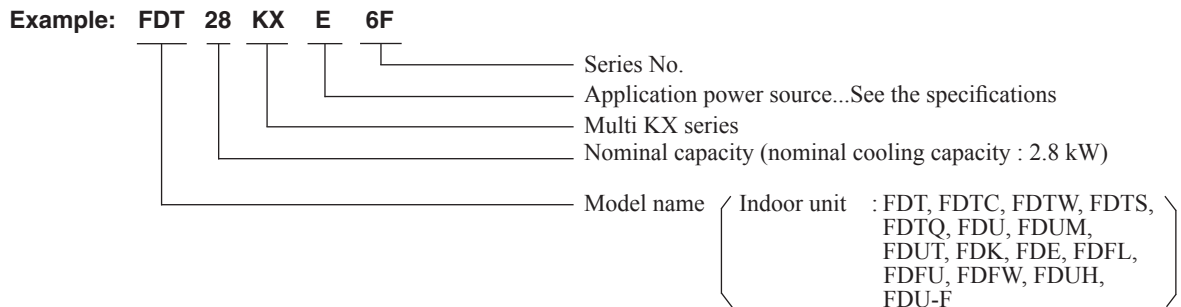

1.3 Table of models

Model	Capacity													
	15	22	28	36	45	56	71	90	112	140	160	224	280	
Ceiling cassette-4 way type (FDT)			○	○	○	○	○	○	○	○	○			
Ceiling cassette-4 way compact type (FDTC)	○	○	○	○	○	○								
Ceiling cassette-2 way type (FDTW)			○		○	○	○	○	○	○				
Ceiling cassette-1 way type (FDTS)					○		○							
Ceiling cassette-1 way compact type (FDTQ)		○	○	○										
Duct connected-High static pressure type (FDU)					○	○	○	○	○	○	○	○	○	
Duct connected-Low/Middle static pressure type (FDUM)		○	○	○	○	○	○	○	○	○	○			
Duct connected (thin)-Low static pressure type (FDUT)	○	○	○	○	○	○	○							
Wall mounted type (FDK)		○	○	○	○	○	○							
Ceiling suspended type (FDE)				○	○	○	○		○	○				
Floor standing (with casing) type (DFL)							○							
Floor standing (without casing) type (FDU)			○		○	○	○							
Floor standing-2 way type (FDFW)		○		○	○									
Duct connected-compact and Flexible type (FDUH)		○	○	○										
Outdoor air processing unit (FDU-F)								○ (500)		○ (850)		○ (1300)	○ (1800)	
Outdoor units to be combined (FDC)	FDC224KXZXE1-FDC1000KXZXE1													

Note (1) Reference No. of data book : '14-KX-DB-206

1.4 Outdoor units combination table

Models	Item	Combination outdoor unit models			Indoor unit	
		FDC224 KXZE1	FDC280 KXZE1	FDC335 KXZE1	Connectable capacity	Number of connectable units
FDC450KXZE1		2	-	-	360 – 900	2 to 60 units
FDC500KXZE1		1	1	-	400 – 800	2 to 53 units
FDC560KXZE1		-	2	-	448 – 896	2 to 59 units
FDC615KXZE1		-	1	1	492 – 984	2 to 65 units
FDC670KXZE1		-	-	2	536 – 1072	2 to 71 units
FDC735KXZE1		2	1	-	588 – 1176	3 to 78 units
FDC800KXZE1		1	2	-	640 – 1280	3 to 80 units
FDC850KXZE1		-	3	-	680 – 1360	3 to 80 units
FDC900KXZE1		-	2	1	720 – 1440	3 to 80 units
FDC950KXZE1		-	1	2	760 – 1520	3 to 80 units
FDC1000KXZE1		-	-	3	800 – 1600	3 to 80 units

(a) Outdoor unit side branch pipe set (Option)

Outdoor unit	Branch pipe set
For two units (for FDC450KXZE1-670KXZE1)	DOS-2A-3
For three units (for FDC730KXZE1-1000KXZE1)	DOS-3A-3

Note (1) Be sure to use this when combining units.

(b) Branch pipe set (Option)

Total capacity downstream	Branching pipe set
Less than 180	DIS-22-1G
180 or more but less than 371	DIS-180-1G
371 or more but less than 540	DIS-371-1G
540 or more	DIS-540-3

(c) Header pipe set (Option)

Total capacity downstream	Header set model type	Number of branches
Less than 180	HEAD4-22-1G	4 branches at the most
180 or more but less than 371	HEAD6-180-1G	6 branches at the most
371 or more but less than 540	HEAD8-371-2	8 branches at the most
540 or more	HEAD8-540-3	8 branches at the most

2. OUTDOOR UNIT

2.1 Specifications

• Single use (Used also for combination)

Models		FDC224KXZE1	FDC280KXZE1	FDC335KXZE1
Nominal cooling capacity *1	kW	22.4	28.0	33.5
Nominal heating capacity *2		25.0	31.5	37.5
Power source		3 Phase 380-415V 50Hz / 380V 60Hz		
Power consumption	Cooling	4.98	6.95	8.68
	Heating	5.56	6.83	8.39
Running current	Cooling	8.7 / 8.0	11.7 / 10.7	14.7 / 13.4
	Heating	9.6 / 8.8	11.7 / 10.7	14.3 / 13.1
Power factor	Cooling	87 / 87	90 / 90	90 / 90
	Heating	88 / 88	89 / 89	89 / 89
Sound pressure level	dB(A)	56 / 57	56 / 56	62 / 57
Exterior dimensions		1690×1350×720		
Height × Width × Depth		2048×1350×720		
Net weight		280		
Refrigerant equipment		GTC5150NC47LF×1		
Compressor type & Q'ty		GUC5185ND47V×1		
Motor		3.23×1	4.60×1	5.72×1
Starting method		Direct line starting		
Crankcase heater		33×1	40×1	
Refrigerant equipment		M fin & inner grooved tubing		
Heat exchanger		Electronic expansion valve		
Refrigerant control		R410A		
Refrigerant		R410A		
Quantity		11.0	11.5	
Refrigerant oil		2.25(M-MA32R)	2.9(M-MA32R)	
Defrost control		Microcomputer controlled De-Icer		
Air handling equipment		Propeller fan × 2		
Fan type & Q'ty		386×2		
Motor		W		
Starting method		Direct start		
Air flow (Standard)		220 / 200	220 / 200	280 / 200
Static pressure		Pa		
Shock & vibration absorber		Rubber mount (for compressor)		
Safety equipment		Compressor overheat protection / Overcurrent protection Power transistor overheating / Protection / Abnormal high pressure protection		
Installation data		Liquid line:φ9.52(3/8")		
Refrigerant piping size		Gas line:φ19.05(3/4")	Gas line:φ22.22(7/8")	Liquid line:φ12.7(1/2") Gas line:φ25.4(1") (φ22.22(7/8"))
Connecting method		Gas line:Brazing / Liquid line:Flare		
MAX. Pressure		High 4.15 Low 2.21		
Drain		Hole for drain (φ20 × 10pcs , φ45 × 3pcs)		
Insulation for piping		Necessary (both Liquid & Gas lines)		
Accessories		-		
Exterior dimensions		PCB003Z858	PCB003Z859	PCB003Z859
Electrical wiring		PCB003Z860	PCB003Z861	PCB003Z861

Notes (1) The data are measured at the following conditions.

Item	Indoor air temperature		Outdoor air temperature		Standards
	DB	WB	DB	WB	
Cooling*1	27 °C	19 °C	35 °C	24 °C	ISO-T1
Heating*2	20 °C	-	7 °C	6 °C	

Adapted to RoHS directive

(2) This packaged air-conditioner is manufactured and tested in conformity with the following standard.

ISO-T1 "UNITARY AIR-CONDITIONERS"

(3) Refrigerant piping size applicable to European installations are shown in parentheses.

PCB003Z839

Models			FDC450KXZXE1	FDC500KXZXE1	FDC560KXZXE1	FDC615KXZXE1	FDC670KXZXE1																										
Combination unit			FDC224KXZXE1	FDC224KXZXE1	FDC280KXZXE1	FDC280KXZXE1	FDC335KXZXE1																										
			FDC224KXZXE1	FDC280KXZXE1	FDC280KXZXE1	FDC335KXZXE1	FDC335KXZXE1																										
Power source			3 Phase 380-415V 50Hz / 380V 60Hz																														
Nominal cooling capacity *1		kW	45.0	50.0	56.0	61.5	67.0																										
Nominal heating capacity *2		kW	50.0	56.0	63.0	69.0	75.0																										
Power consumption		Cooling	10.0	11.8	13.9	15.6	17.4																										
		Heating	11.1	12.3	13.7	15.2	16.8																										
Running current		Cooling	17.5 / 16.0	20.0 / 18.5	23.5 / 21.5	26.4 / 24.1	29.3 / 26.8																										
		Heating	19.2 / 17.6	21.2 / 19.4	23.3 / 24.4	26.0 / 23.8	28.6 / 26.2																										
Power factor		Cooling	87 / 87	89 / 89	90 / 90	90 / 90	90 / 90																										
		Heating	88 / 88	88 / 88	89 / 89	89 / 89	89 / 89																										
Net weight		kg	560	605	650	650	650																										
Refrigerant piping size		Liquid line	φ12.7																														
		Gas line	φ28.58																														
		Oil equalization	φ9.52																														
Models			FDC735KXZXE1	FDC800KXZXE1	FDC850KXZXE1	FDC900KXZXE1	FDC950KXZXE1	FDC1000KXZXE1																									
Combination unit			FDC224KXZXE1	FDC224KXZXE1	FDC280KXZXE1	FDC280KXZXE1	FDC280KXZXE1	FDC335KXZXE1																									
			FDC224KXZXE1	FDC280KXZXE1	FDC280KXZXE1	FDC280KXZXE1	FDC335KXZXE1	FDC335KXZXE1																									
			FDC280KXZXE1	FDC280KXZXE1	FDC280KXZXE1	FDC335KXZXE1	FDC335KXZXE1	FDC335KXZXE1																									
Power source			3 Phase 380-415V 50Hz / 380V 60Hz																														
Nominal cooling capacity*1		kW	73.5	80.0	85.0	90.0	95.0	100.0																									
Nominal heating capacity*2		kW	82.5	90.0	95.0	100.0	106.0	112.0																									
Power consumption		Cooling	17.1	19.3	21.1	22.7	24.3	25.9																									
		Heating	18.2	19.7	20.6	21.9	23.5	25.1																									
Running current		Cooling	29.4 / 27.0	32.9 / 30.1	35.6 / 32.6	38.4 / 35.1	41.0 / 37.6	43.7 / 40.0																									
		Heating	31.4 / 28.7	33.5 / 30.7	35.2 / 32.2	37.4 / 34.3	40.1 / 36.7	42.8 / 39.2																									
Power factor		Cooling	88 / 88	89 / 89	90 / 90	90 / 90	90 / 90	90 / 90																									
		Heating	88 / 88	89 / 89	89 / 89	89 / 89	89 / 89	89 / 89																									
Net weight		kg	885	930	975	975	975	975																									
Refrigerant piping size		Liquid line	φ15.88																														
		Gas line	φ31.75(φ34.92)					φ38.1																									
		Oil equalization	φ9.52																														
Notes (1) The data are measured at the following conditions.																																	
<table border="1"> <thead> <tr> <th rowspan="2">Item</th> <th colspan="2">Indoor air temperature</th> <th colspan="2">Outdoor air temperature</th> <th rowspan="2">Standards</th> </tr> <tr> <th>DB</th> <th>WB</th> <th>DB</th> <th>WB</th> </tr> </thead> <tbody> <tr> <td>Operation</td> <td></td> <td></td> <td></td> <td></td> <td rowspan="3">ISO-T1</td> </tr> <tr> <td>Cooling*1</td> <td>27 °C</td> <td>19 °C</td> <td>35 °C</td> <td>24 °C</td> </tr> <tr> <td>Heating*2</td> <td>20 °C</td> <td>-</td> <td>7 °C</td> <td>6 °C</td> </tr> </tbody> </table>								Item	Indoor air temperature		Outdoor air temperature		Standards	DB	WB	DB	WB	Operation					ISO-T1	Cooling*1	27 °C	19 °C	35 °C	24 °C	Heating*2	20 °C	-	7 °C	6 °C
Item	Indoor air temperature		Outdoor air temperature		Standards																												
	DB	WB	DB	WB																													
Operation					ISO-T1																												
Cooling*1	27 °C	19 °C	35 °C	24 °C																													
Heating*2	20 °C	-	7 °C	6 °C																													
Adapted to RoHS directive																																	
(2) This packaged air-conditioner is manufactured and tested in conformity with the following standard. ISO-T1 "UNITARY AIR-CONDITIONERS"																																	
(3) Refrigerant piping size applicable to European installations are shown in parentheses.																																	

PCB003Z839

2.2 Exterior dimensions

Models FDC224KXZE1

Dimensions of refrigerant piping connection pipe (ichnography)

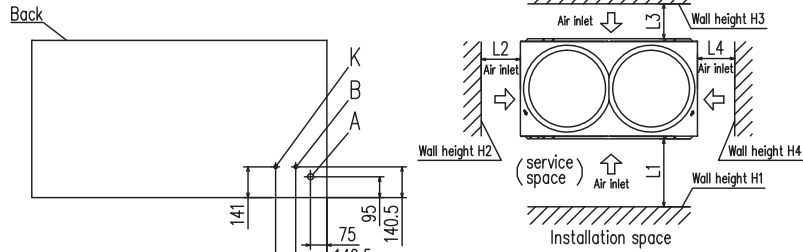

MARK	Content	
A	Refrigerant gas piping connection pipe	∅19.05 (Brazing)
B	Refrigerant liquid piping connection pipe	∅9.52 (Flare)
C	Refrigerant piping exit hole	∅88 (or ∅100)
D	Power supply entry hole	∅50 (Right-Left-Front), Long hole 40X80 (Bottom)
F	Anchor bolt hole	M10, 4pcs.
G	Drain waste water hose hole	∅45, 3pcs.
H	Drain hole	∅20, 10pcs.
K	Refrigerant oil equalization piping connection pipe	∅9.52 (Flare)
L	Carrying in or hole for hanging	230X60

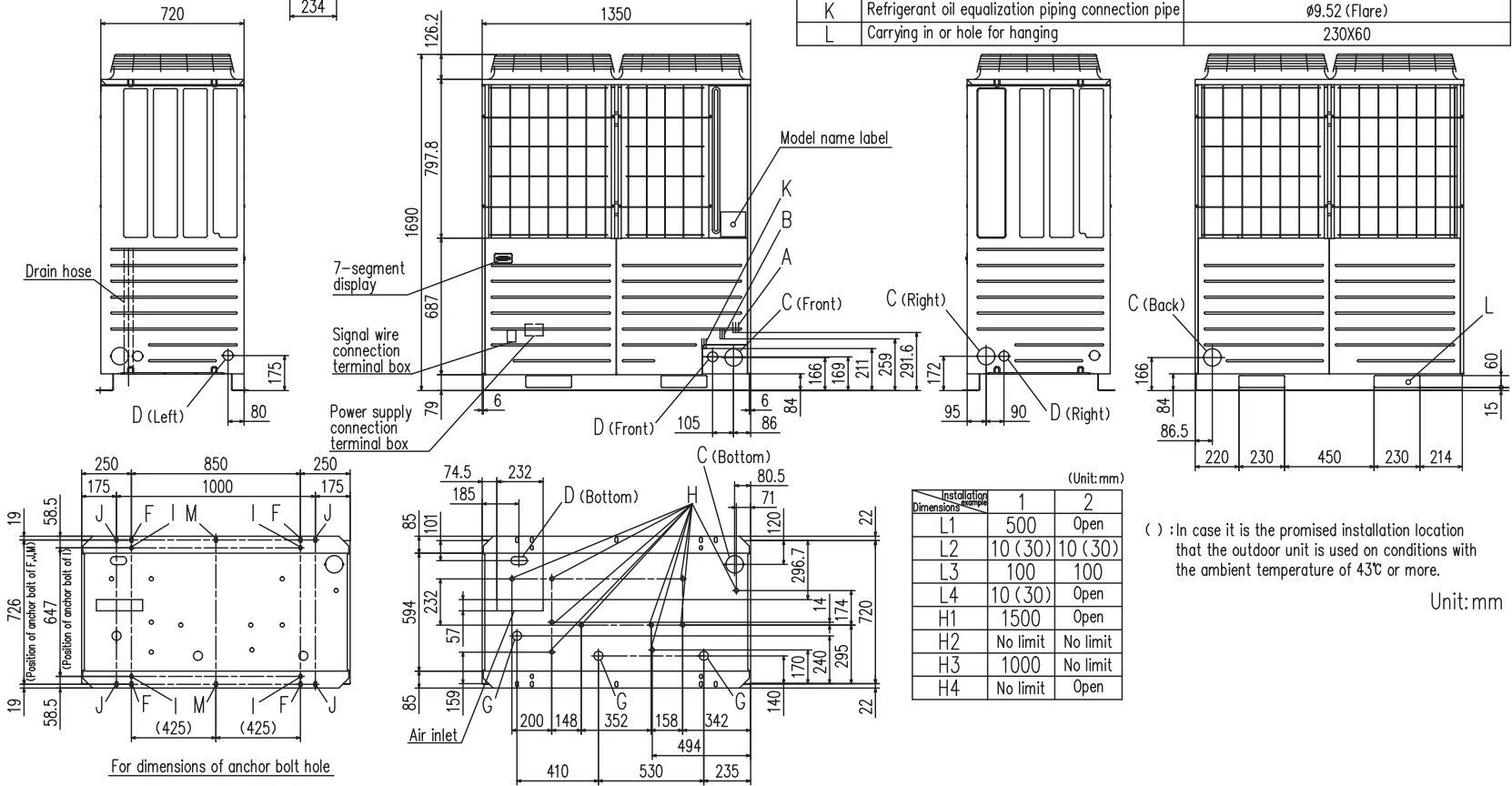

(Unit: mm)

Installation Dimensions	1	2
L1	500	Open
L2	10 (30)	10 (30)
L3	100	100
L4	10 (30)	Open
H1	1500	Open
H2	No limit	No limit
H3	1000	No limit
H4	No limit	Open

() : In case it is the promised installation location that the outdoor unit is used on conditions with the ambient temperature of 43°C or more.

Unit: mm

PCB003Z858

PCB003Z859

Dimensions of refrigerant piping connection pipe (ichnography)

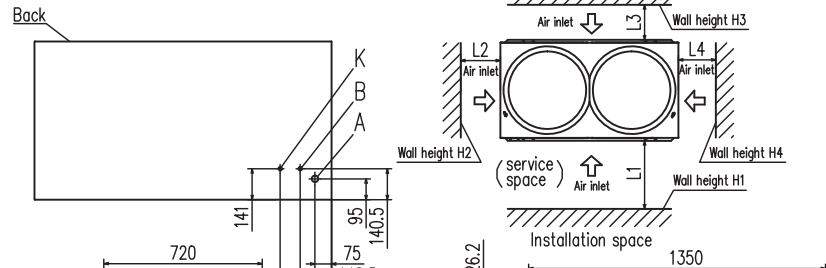

MARK	Content	
A	Refrigerant gas piping connection pipe	280: Ø22.22 (Brazing) 335: Ø25.4 (Brazing)
B	Refrigerant liquid piping connection pipe	280: Ø9.52 (Flare) 335: Ø12.7 (Flare)
C	Refrigerant piping exit hole	Ø88 (or Ø100)
D	Power supply entry hole	Ø50 (Right-Left-Front), Long hole 40X80 (Bottom)
F	Anchor bolt hole	M10, 4pcs.
G	Drain waste water hose hole	Ø45, 3pcs.
H	Drain hole	Ø20, 10pcs.
K	Refrigerant oil equalization piping connection pipe	Ø9.52 (Flare)
L	Carrying in or hole for hanging	230X60

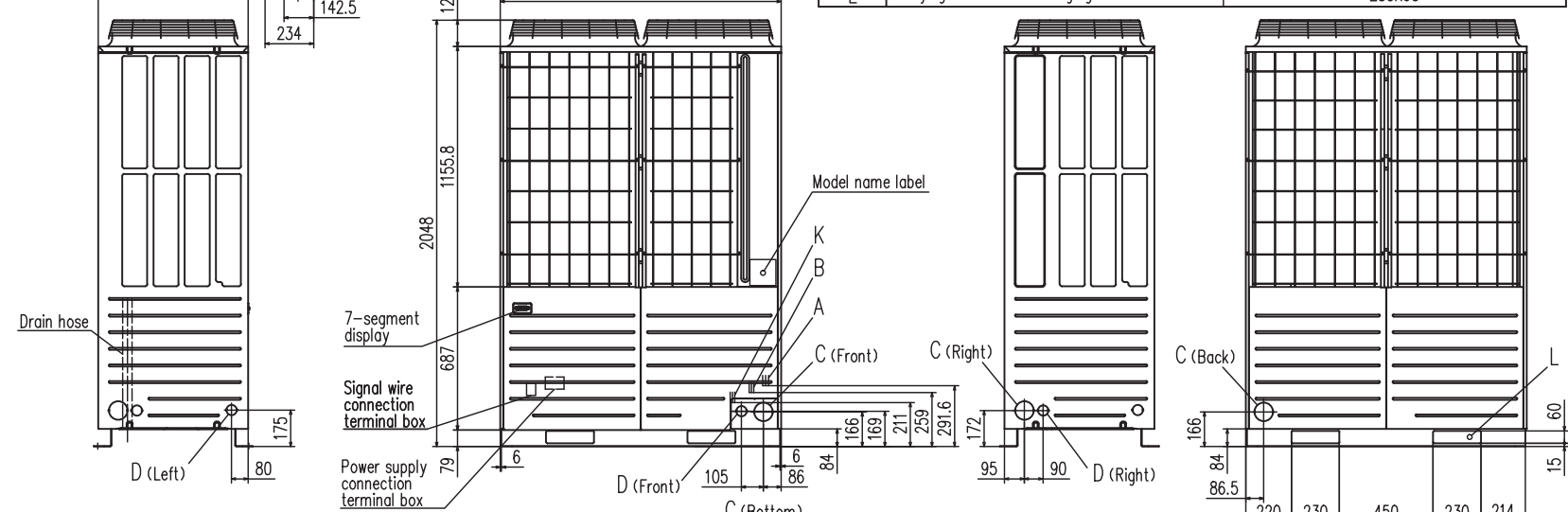

(Unit:mm)

Installation example Dimensions	1	2
L1	500	Open
L2	10 (30)	10 (30)
L3	100	100
L4	10 (30)	Open
H1	1500	Open
H2	No limit	No limit
H3	1000	No limit
H4	No limit	Open

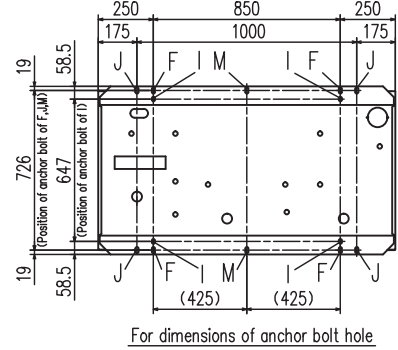

() : In case it is the promised installation location that the outdoor unit is used on conditions with the ambient temperature of 43°C or more.

Unit:mm

Models FDC280KXZXE1, 335KXZXE1

2.3 Electrical wiring

Models FDC224KXZE1

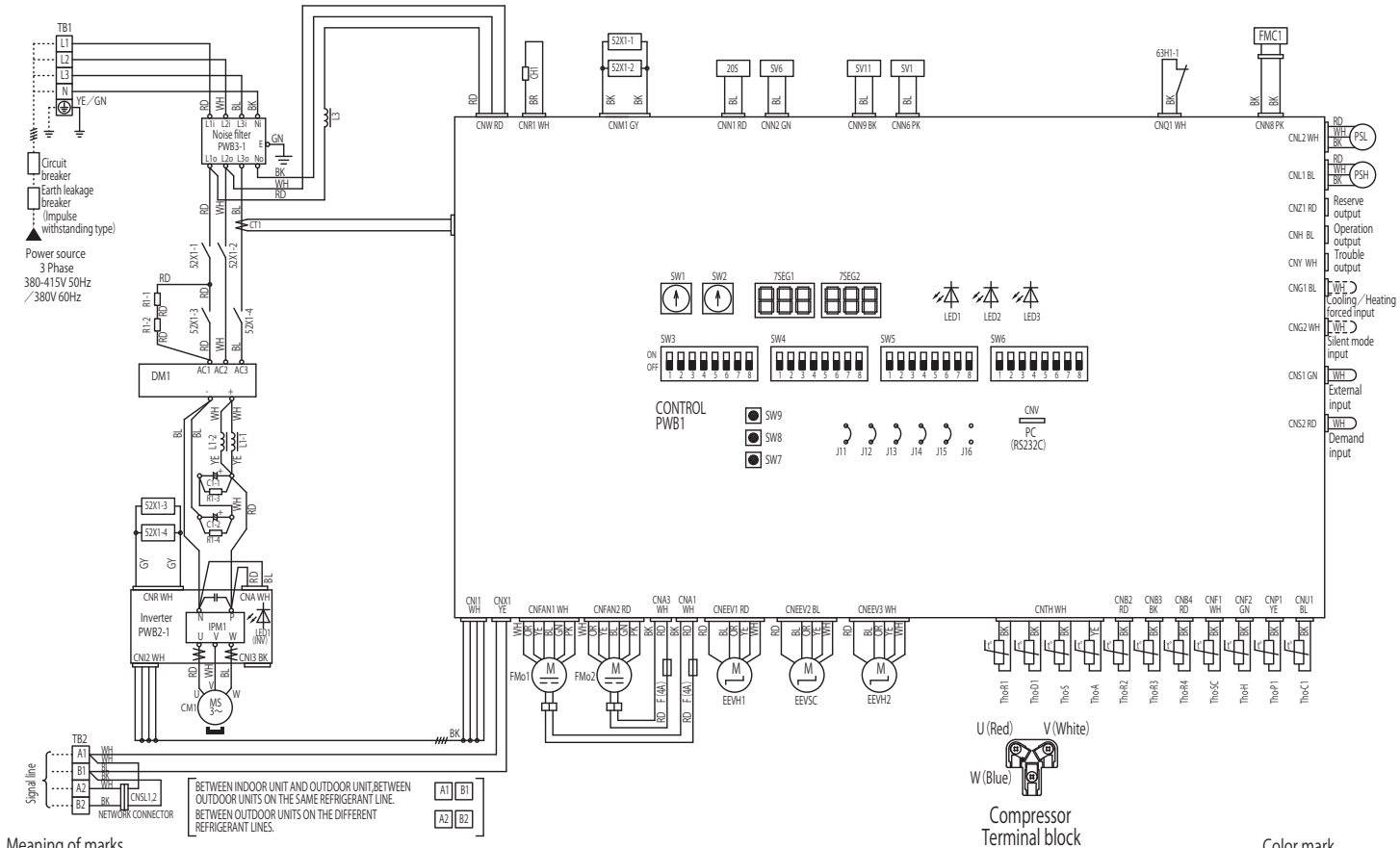

Meaning of marks

Mark	Parts name
CH1	Crankcase heater
CM1	Compressor motor
CNA-Z	Connector
CT1	Current sensor
CI-1,2	Electrolytic capacitor
DM1	Diode module
EEVH1,2	Expansion valve for heating
EEVSC	Expansion valve for SC
F	Fuse
FMC1	Fan for IPM
FMo1,2	Blower motor
IPM	Intelligent power module
J11,12	Set up model (volt)
J13	External input select level / pulse
J14	Defrost recover temp
J15	Defrost start temp
J16	Spare
LED1	Inspection (Red)
LED1 (INV)	Normal (Yellow) -Flashing
LED2	Normal (Green)
LED3	Service (green for service)
L1-1,2	D.C.reactior
L3	D.C.reactior

Mark	Parts name
PSH	High pressure sensor
PSL	Low pressure sensor
PWB1-3	Printed wiring board (PCB)
RT-1-1-4	Rush current suppression resistor
SV1	Solenoid valve (CM1.bypass)
SV6	Solenoid valve (oil separator CM1)
SV11	Solenoid valve (gas bypass)
SW1	Address setting SW outdoor unit No.(2 digits)
SW2	Address setting SW outdoor unit No.(1 digit)
SW3-1	Inspection LED reset
SW3-2	Auto backup operation
SW3-3	Regular operation
SW3-4	Spare
SW3-5	Refrigerant quantity check
SW3-6	Regular operation
SW3-7	Check operation
SW3-8	Regular operation
SW3-9	Spare

Mark	Parts name
SW4-1-4	Model setting
SW4-5	Spare
SW4-6	Spare
SW4-7	Address setting switch (master+slave)
SW4-8	Address setting switch (master+slave)
SW5-1	ON Trial operation
SW5-2	OFF Regular operation
SW5-3	ON Trial operation mode / cooling
SW5-4	OFF Trial operation mode / heating
SW5-5	ON Pump down operation
SW5-6	OFF Regular operation
SW5-7	Spare
SW5-8	ON Super Link I communication
SW5-9	OFF Super Link II communication
SW6-1-3	Spare
SW6-4	ON High Head
SW6-5	OFF Standard
SW7	Data clear / insert
SW8	7-segment indicate (unit's place)
SW9	7-segment indicate (ten's place)

Mark	Parts name
TB1,2	Terminal block
Tho-A	External air thermistor
Tho-C1	Under-dome thermistor
Tho-D1	Discharge pipe thermistor
Tho-H	Sub-cooling coil thermistor 2
Tho-P1	Power transistor thermistor
Tho-R1	Heat exchanger thermistor (exhaust)
Tho-R2	Heat exchanger thermistor (exhaust)
Tho-R3	Heat exchanger thermistor (inlet)
Tho-R4	Heat exchanger thermistor (inlet)
Tho-S	Suction pipe thermistor
Tho-SC	Sub-cooling coil thermistor 1
Z05	4way valve
SZ2X1-1-4	Solenoid for CM
63H1-1	High pressure switch (for protection)
7SEG1	7-segment L.E.D. (function indication)
7SEG2	7-segment L.E.D. (data indication)

Color mark

Mark	Color
BK	Black
BL	Blue
BR	Brown
GN	Green
GY	Gray
OR	Orange
RD	Red
WH	White
YE	Yellow
PK	Pink
YE/GN	Yellow / Green

PCB003Z860

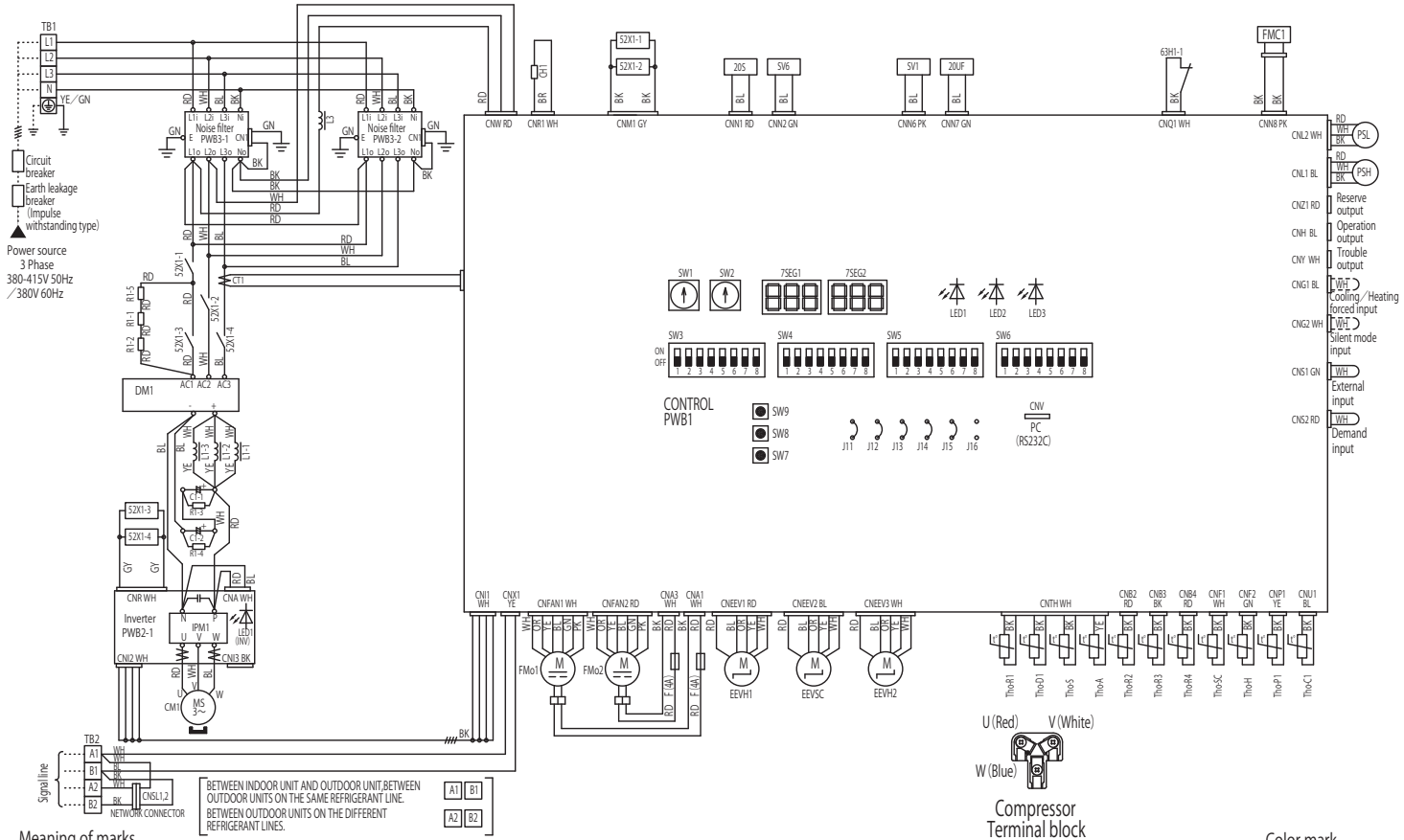

Meaning of marks

Mark	Parts name
CH1	Crankcase heater
CM1	Compressor motor
CNA-Z	Connector
CT1	Current sensor
CI-1,2	Electrolytic capacitor
DM1	Diode module
EEVH1,2	Expansion valve for heating
EEVSC	Expansion valve for SC
F	Fuse
FMC1	Fan for IPM
FMo1,2	Blower motor
IPM	Intelligent power module
JT1,12	Set up model (volt)
J13	External input select level / pulse
J14	Defrost recover temp
J15	Defrost start temp
J16	Spare
LED1	Inspection (Red)
LED1 (INV)	Normal (Yellow)-Flashing
LED2	Normal (Green)
LED3	Service (green for service)
L1-1-3	D.C.reactior
L3	D.C.reactior

Mark	Parts name
PSH	High pressure sensor
PSL	Low pressure sensor
PWB1-3	Printed wiring board (PCB)
R1-1-1-5	Rush current suppression resistor
SV1	Solenoid valve (CM1.bypass)
SV6	Solenoid valve (oil separator CM1)
SW1	Address setting SW outdoor unit No.2 (4digs)
SW2	Address setting SW outdoor unit No.1 (1 digit)
SW3-1	Inspection LED reset
SW3-2	ON Auto backup operation
OFF	Regular operation
SW3-3	Spare
SW3-4	ON Refrigerant quantity check
OFF	Regular operation
SW3-5	ON Check operation
OFF	Regular operation
SW3-6	Spare
SW3-7	ON Forced cooling / heating
OFF	Regular operation
SW3-8	Spare

Mark	Parts name
SW4-1-4	Model setting
SW4-5	Spare
SW4-6	Spare
SW4-7	Address setting switch (master-slave)
SW4-8	Address setting switch (master-slave)
SW5-1	ON Trial operation
OFF	Regular operation
SW5-2	ON Trial operation mode / cooling
OFF	Trial operation mode / heating
SW5-3	ON Pump down operation
OFF	Regular operation
SW5-4	Spare
SW5-5	ON Super Link I communication
OFF	Super Link II communication
SW5-6-8	Spare
SW6-1-3	Spare
SW6-4	ON High Head
OFF	Standard
SW7	Data clear / insert
SW8	7-segment indicate (unit's place)
SW9	7-segment indicate (ten's place)

Mark	Parts name
TB1,2	Terminal block
Tho-A	External air thermistor
Tho-C1	Under-dome thermistor
Tho-D1	Discharge pipe thermistor
Tho-H	Sub-cooling coil thermistor 2
Tho-P1	Power transistor thermistor
Tho-R1	Heat exchanger thermistor (exhaust)
Tho-R2	Heat exchanger thermistor (exhaust)
Tho-R3	Heat exchanger thermistor (inlet)
Tho-R4	Heat exchanger thermistor (inlet)
Tho-S	Suction pipe thermistor
Tho-SC	Sub-cooling coil thermistor 1
20S	4way valve
20UF	Capacity control
52X1-1-1-4	Solenoid for CM1
63H1-1	High pressure switch (for protection)
7SEG1	7-segment L.E.D.(function indication)
7SEG2	7-segment L.E.D.(data indication)

Color mark

Mark	Color
BK	Black
BL	Blue
BR	Brown
GN	Green
GY	Gray
OR	Orange
RD	Red
WH	White
YE	Yellow
PK	Pink
YE / GN	Yellow / Green

PCB003Z861

2.4 Noise level

Measured based on JIS B 8616

Mike position as highest noise level in position as below

Distance from front side 1m

Height 1m

Model FDC224KXZXE1

Noise level 56 dB (A) at cooling
57 dB (A) at heating

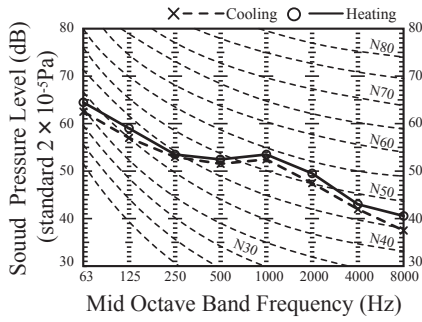

Model FDC280KXZXE1

Noise level 56 dB (A) at cooling
56 dB (A) at heating

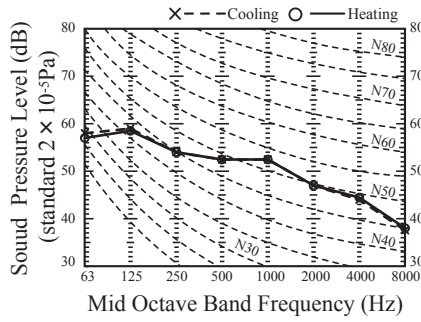

Model FDC355KXZXE1

Noise level 62 dB (A) at cooling
57 dB (A) at heating

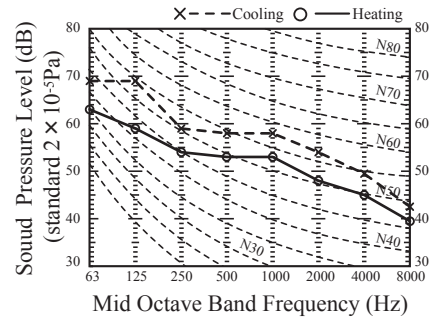

3. RANGE OF USAGE & LIMITATIONS

• Single use (also for combination use)

System		FDC224KXZXE1	FDC280KXZXE1	FDC335KXZXE1
Item				
Indoor air temperature (Upper, lower limits)		Refer to page 15		
Outdoor air temperature (Upper, lower limits)				
Indoor units that can be used in combination	Number of connected units	1 to 29 units	1 to 37 units	1 to 44 units
	Connectable capacity ⁽¹⁾	180 - 448	224 - 560	268 - 670
Total piping length ⁽²⁾		1000m or less		
Main pipe length		130m or less		
Single direction piping length		Actual length : 160m or less, Equivalent length : 185m or less		
Allowable pipe length from the first branching		90m or less (However, difference between the longest and shortest piping : 40m or less ⁽⁶⁾)		
Elevation difference between the first branching point and the indoor unit		18m or less		
Difference in height between indoor and outdoor units	Outdoor unit is higher	50m or less (Max. 70m or less) ⁽⁵⁾		
	Outdoor unit is lower	40m or less ⁽³⁾		
Difference in the elevation of indoor units in a system		18m or less		
Indoor unit atmosphere (behind ceiling) temperature and humidity (Only models FDT, FDTC, FDTW, FDTS, FDTQ, FDU, FDUM, FDUT, FDUH, FDU-F)		Dew point temperature 28 °C or less, relative humidity 80% or less (FDE, FDK, FDFL, FDFU, FDFW : Dew point temperature 23 °C or less, relative humidity 80% or less)		
Compressor stop/start frequency	1 cycle time	5 min or more (from stop to stop or from start to start)		
	Stop time	3 min or more		
Power source voltage	Voltage fluctuation	Within ±10% of rated voltage		
	Voltage drop during start	Within -15% of rated voltage		
	Phase unbalance	Within 3%		

Note (1) When connecting the indoor unit type FDK, FDFL, FDFU or FDFW series, limit the connectable capacity not higher than 130%.

(2) When the pipe extension length exceeds 510 m, additional refrigerant oil must be charged (1,000 cc).

(3) It must be less than 30 m when conducting the cooling operation with the outdoor air temperature lower than 10 °C.

(4) If Superlink I (previous Superlink) is selected, all the range of usage and limitations, not only the limitations of connectable indoor capacity and connectable number of indoor unit but also of the piping length, operating temperature range and etc., become same as those of KX4 (See technical manual '07-KX-KXR-T-114). In addition to above limitations, all of new functions for KX6 and KXZ such as automatic address setting function for multiple refrigerant systems and etc. will be cancelled.

(5) When it is required to install in a range of 50 to 70 m, the limitation of use, etc. are different from those described here. For details, refer to page 16.

(6) When it is required to install in the difference between the longest and shortest piping more than 40m, refer to page 17.

Allowable length of refrigerant piping, height difference between indoor and outdoor unit

(1) Branch pipe system (Branch piping used)

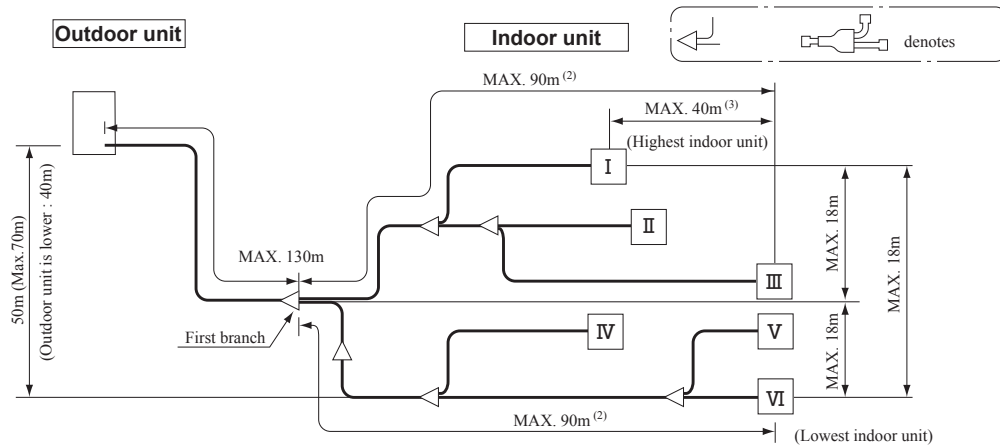

(2) Header system (Header used)

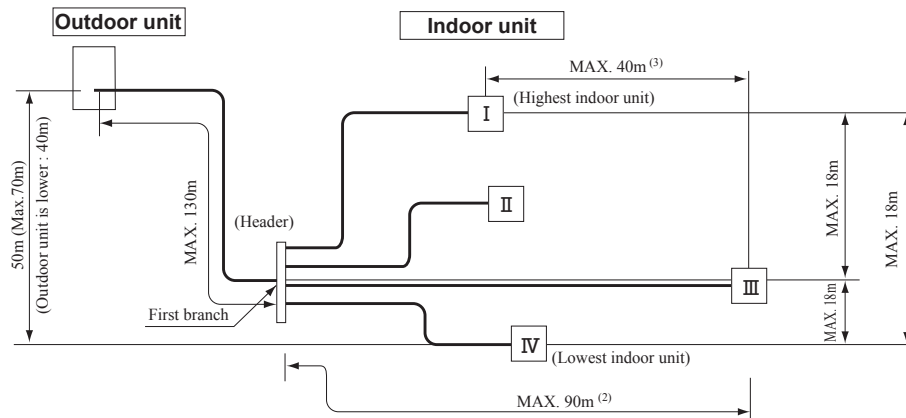

(3) Mixed system (Branch piping and header used)

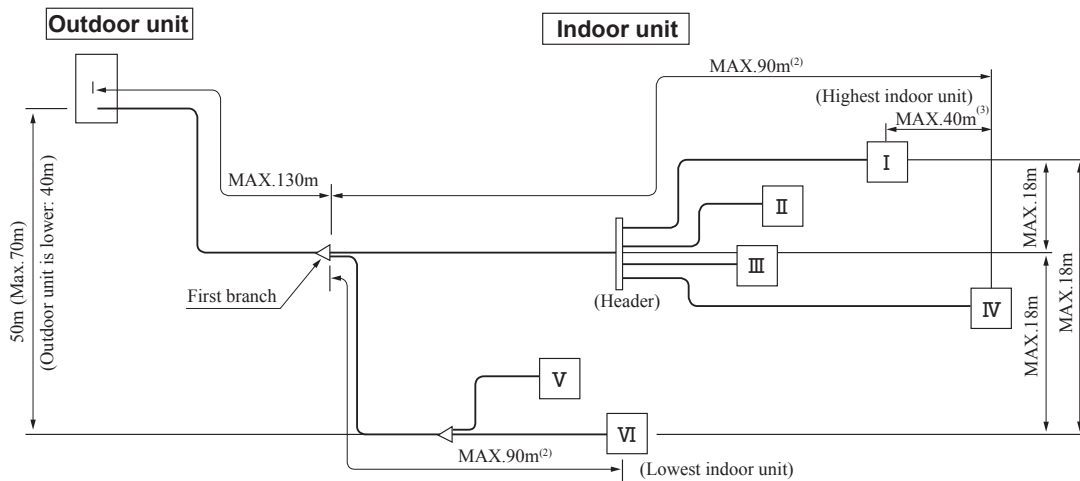

Note (1) A branch piping system cannot be connected after a header system.

(2) 90m or less (However, difference between the longest and shortest piping : 40m or less ⁽³⁾)

(3) When it is required to install the difference between the longest and shortest piping more than 40m, refer to page 17.

Important

When the Additional refrigerant quantity (S+P+I) is over the following table, please separate the refrigerant line.

Outdoor unit	S+P+I (kg)
224-670	45
735-1000	90

S: Standard additional refrigerant quantity (kg)

P: Additional refrigerant quantity for piping (kg)

I: Additional refrigerant quantity for indoor units (kg)

• Combination use

System		FDC450KXZXE1	FDC500KXZXE1	FDC560KXZXE1	FDC615KXZXE1	FDC670KXZXE1	
		Item					
Indoor air temperature (Upper, lower limits)		Refer to page 15					
Outdoor air temperature (Upper, lower limits)							
Indoor units that can be used in combination	Number of connected units	2 to 60 units	2 to 53 units	2 to 59 units	2 to 65 units	2 to 71 units	
	Connectable capacity ⁽¹⁾	360 – 900	400 – 800	448 – 896	492 – 984	536 – 1072	
Total piping length ⁽²⁾		1000m or less					
Single direction piping length		Actual length : 160m or less, Equivalent length : 185m or less					
Main pipe length		130m or less					
Allowable pipe length from the first branching		90m or less (However, difference between the longest and shortest piping : 40m or less ⁽⁶⁾)					
Elevation difference between the first branching point and the indoor unit		18m or less					
Difference in height between indoor and outdoor units	Outdoor unit is higher	50m or less (Max.70m or less) ⁽⁵⁾					
	Outdoor unit is lower	40m or less ⁽³⁾					
Difference in the elevation of indoor units in a system		18m or less					
Difference in height between outdoor units (Same system)		MAX. 0.4m					
Difference between an outdoor unit and on outdoor unit side branch pipe		MAX. 5m					
Length of oil equalization piping		MAX. 10m					
Indoor unit atmosphere (behind ceiling) temperature and humidity Only models FDT, FDTC, FDTW, FDTS, FDTQ, FDU, FDUM, FDUT, FDUH, FDU-F		Dew point temperature 28 °C or less, relative humidity 80% or less (FDE, FDK, FDFL, FDFU, FDFW : Dew point temperature 23 °C or less, relative humidity 80% or less)					
Compressor stop/start frequency	1 cycle time	5 min or more (from stop to stop or from start to start)					
	Stop time	3 min or more					
Power source voltage	Voltage fluctuation	Within ±10% of rated voltage					
	Voltage drop during start	Within -15% of rated voltage					
	Phase unbalance	Within 3%					

System		FDC735KXZXE1	FDC800KXZXE1	FDC850KXZXE1	FDC900KXZXE1	FDC950KXZXE1	FDC1000KXZXE1	
		Item						
Indoor air temperature (Upper, lower limits)		Refer to page 15						
Outdoor air temperature (Upper, lower limits)								
Indoor units that can be used in combination	Number of connected units	3 to 78 units	3 to 80 units	3 to 80 units	3 to 80 units	3 to 80 units	3 to 80 units	
	Connectable capacity	588 – 1176	640 – 1280	680 – 1360	720 – 1440	760 – 1520	800 – 1600	
Total piping length ⁽²⁾		1000m or less						
Single direction piping length		Actual length : 160m or less, Equivalent length : 185m or less						
Main pipe length		130m or less						
Allowable pipe length from the first branching		90m or less (However, difference between the longest and shortest piping : 40m or less ⁽⁶⁾)						
Elevation difference between the first branching point and the indoor unit		18m or less						
Difference in height between indoor and outdoor units	Outdoor unit is higher	50m or less (Max.70m or less) ⁽⁵⁾						
	Outdoor unit is lower	40m or less ⁽³⁾						
Difference in the elevation of indoor units in a system		18m or less						
Difference in height between outdoor units (Same system)		MAX. 0.4m						
Difference between an outdoor unit and on outdoor unit side branch pipe		MAX. 5m						
Length of oil equalization piping		MAX. 10m						
Indoor unit atmosphere (behind ceiling) temperature and humidity Only models FDT, FDTC, FDTW, FDTS, FDTQ, FDU, FDUM, FDUT, FDUH, FDU-F		Dew point temperature 28 °C or less, relative humidity 80% or less (FDE, FDK, FDFL, FDFU, FDFW : Dew point temperature 23 °C or less, relative humidity 80% or less)						
Compressor stop/start frequency	1 cycle time	5 min or more (from stop to stop or from start to start)						
	Stop time	3 min or more						
Power source voltage	Voltage fluctuation	Within ±10% of rated voltage						
	Voltage drop during start	Within -15% of rated voltage						
	Phase unbalance	Within 3%						

- Note (1) When connecting the indoor unit type FDK, FDFL, FDFU or FDFW series, limit the connectable capacity not higher than 130%.
(2) When the pipe extension length exceeds 510 m, additional refrigerant oil must be charged (1,000 cc).
(3) It must be less than 30 m when conducting the cooling operation with the outdoor air temperature lower than 10 °C.
(4) If Superlink I (previous Superlink) is selected, all the range of usage and limitations, not only the limitations of connectable indoor capacity and connectable number of indoor unit but also of the piping length, operating temperature range and etc., become same as those of KX4 (See technical manual '07-KX-KXR-T-114). In addition to above limitations, all of new functions for KX6 and KXZ such as automatic address setting function for multiple refrigerant systems and etc. will be cancelled.
(5) When it is required to install in a range of 50 to 70 m, the limitation of use, etc. are different from those described here. For details, refer to page 16.
(6) When it is required to install in the difference between the longest and shortest piping more than 40m, refer to page 17.

Allowable length of refrigerant piping, height difference between indoor and outdoor unit

(1) Branch pipe system (Branch piping used)

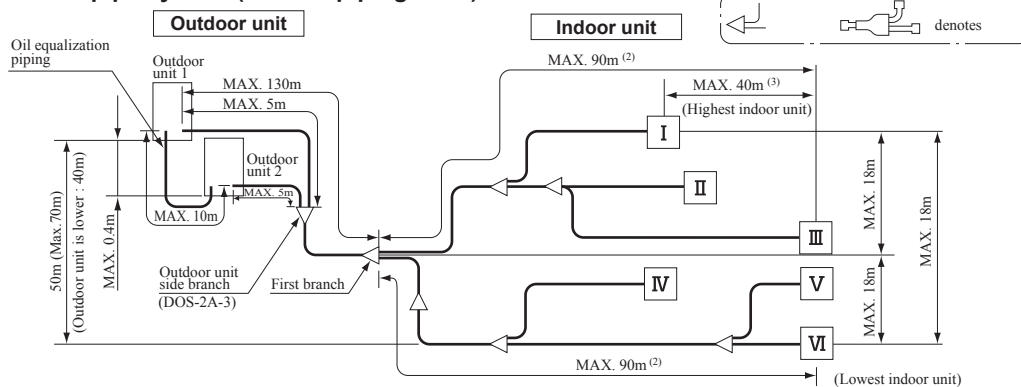

(2) Header system (Header used)

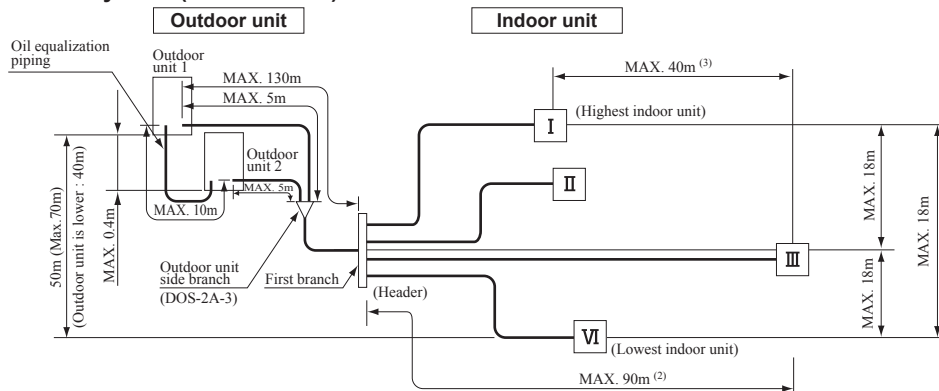

(3) Mixed system (Branch piping and header used)

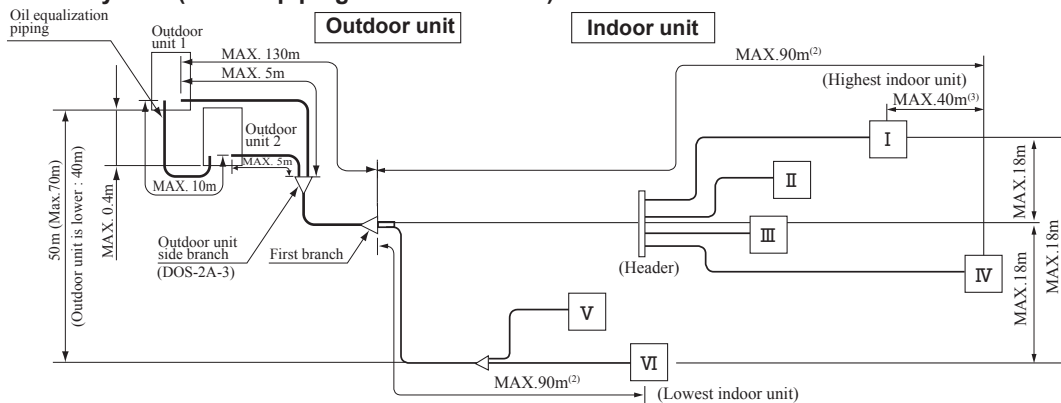

(4) Pipe system for combination of 3 outdoor units (Displaying only outdoor units)

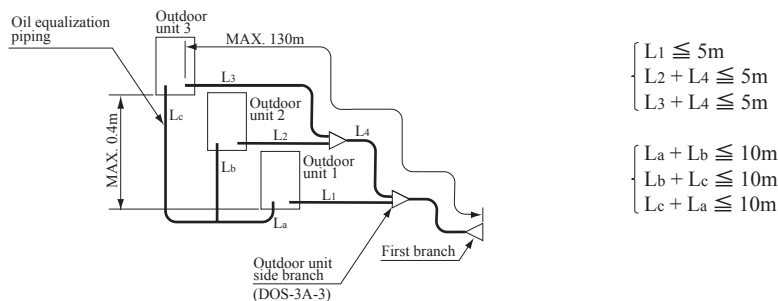

- Note (1) A branch piping system cannot be connected after a header system.
 (2) 90m or less (However, difference between the longest and shortest piping : 40m or less⁽³⁾)
 (3) When it is required to install the difference between the longest and shortest piping more than 40m, refer to page 17.

Important When the Additional refrigerant quantity (S+P+I) is over the following table, please separate the refrigerant line.

Outdoor unit	S + P + I (kg)
224-670	45
735-1000	90

S: Standard additional refrigerant quantity (kg)
 P: Additional refrigerant quantity for piping (kg)
 I: Additional refrigerant quantity for indoor units (kg)

Operating temperature range

Cooling operation

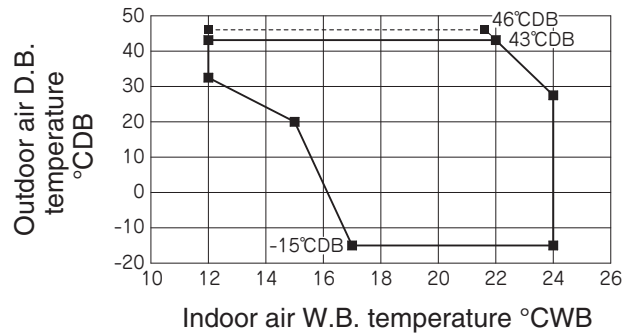

*In case it is the promised installation location that the outdoor unit is used on conditions with the ambient temperature of 43°C or more, refer to page 6 (2.2 Exterior dimensions).

Heating operation

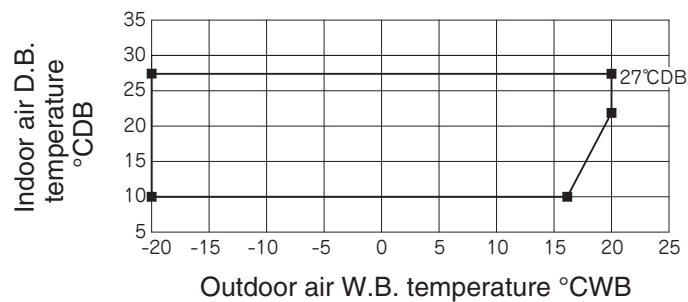

“CAUTION” Cooling operation under low outdoor air temperature conditions

KXZ models can be operated in cooling mode at low outdoor air temperature condition within above temperature range. However in case of severely low temperature conditions if the following precaution is not observed, it may not be operated in spite of operable temperature range mentioned above and cooling capacity may not be established under certain conditions.

[Precaution]

In case of severely low temperature condition

- 1) Install the outdoor unit at the place where strong wind cannot blow directly into the outdoor unit.
- 2) If there is no installation place where can prevent strong wind from directly blowing into the outdoor unit, prepare a windbreak fence or something like that locally in order to divert the strong wind from the outdoor unit.

[Reason]

Under the low outdoor air temperature conditions of -5°C or lower, if strong wind directly blow into the outdoor unit, the outdoor heat exchanger temperature will drop, even though the outdoor fan is stopped by outdoor fan control. This makes high and low pressures to drop as well. This low pressure drop makes the indoor heat exchanger temperature to drop and will activate anti-frost control at indoor heat exchanger at frequent intervals, that cooling operation may not be established for any given time.

Specification for installation with large head difference (Applicable to: FDC224 - 1000KXZXE1)

In case when the outdoor unit is installed at a higher place and **the difference in the elevation between the indoor and the outdoor units is larger than 50 m and smaller than 70 m**, the limitation on application differs partially from ordinary applications and, instead, the following specification applies. The pipe size, refrigerant amount and way of switch setting become also different.

In the range of use, **the outdoor air temperature (lower limit), indoor units allowed to combine, total piping length and difference in the elevation between indoor units in the same system** are different from ordinary applications.

Table 1 Range of use

Item		FDC224-1000KXZXE1
Indoor air temperature (Upper, lower limits)		Refer to Table 2
Outdoor air temperature (Upper, lower limits)		
Indoor units that can be used in combination	Number of connected units	Refer to Table 3
	Connectable capacity	
Total piping length		510m or less
Main pipe length		130m or less
Single direction piping length		Actual length : 160m or less, Equivalent length : 185m or less
Allowable pipe length from the first branching		90m or less (However, difference between the longest and shortest piping : 40m or less)
Allowable difference in the elevation	Elevation difference between the first branching point and the indoor unit	18m or less
	Outdoor unit is higher	50m or more-70m or less
	Outdoor unit is lower	40m or less
	Difference in the elevation of indoor units in a system	15m or less
Limitation on piping from outdoor unit to branching pipe at outdoor unit side	Difference in the elevation	0.4m or less
	Elevation from outdoor unit to branching pipe at outdoor unit side	5m or less
	Oil equalizing pipe length	10m or less
	Length between outdoor branching pipes for a combination of 3 units	5m or less
Indoor unit atmosphere (behind ceiling) temperature and humidity Only models FDT,FDC,FDTW,FDTQ,FDTS,FDU,FDUM,FDUH,FDUT		Dew point temperature 28°C or less, relative humidity 80% or less (FDT,FDK,FDL,FDU,FDW : Dew point temperature 28°C or less, relative humidity 80% or less)
Compressor stop/start frequency	1 cycle time	5 min or less (from stop to stop or from start to start)
	Stop time	3 min or more
Power source voltage	Voltage fluctuation	Within ±10% of rated voltage
	Voltage drop during start	Within -15% of rated voltage
	Phase unbalance	Within 3%

Table 2 Indoor air temperature/Outdoor air temperature

Cooling operation

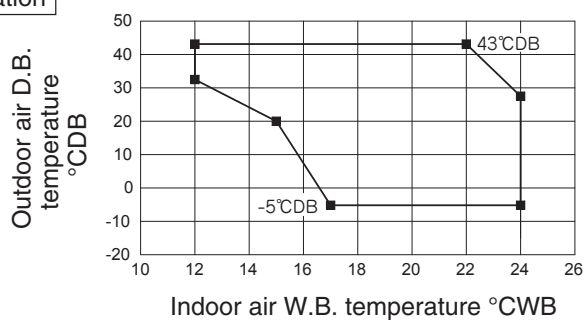

Heating operation

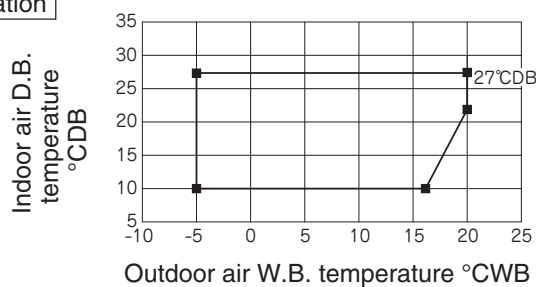

Table 3 Number of connectable indoor units and capacity range

Model/Item	Number of connectable units	Connectable capacity
FDC224KXZXE1	1 to 14	180 - 224
FDC280KXZXE1	1 to 18	224 - 280
FDC335KXZXE1	1 to 22	268 - 335
FDC450KXZXE1	2 to 30	360 - 450
FDC500KXZXE1	2 to 33	400 - 500
FDC560KXZXE1	2 to 37	448 - 560
FDC615KXZXE1	2 to 41	492 - 615
FDC670KXZXE1	2 to 44	536 - 670
FDC735KXZXE1	3 to 49	588 - 735
FDC800KXZXE1	3 to 53	640 - 800
FDC850KXZXE1	3 to 56	680 - 850
FDC900KXZXE1	3 to 60	720 - 900
FDC950KXZXE1	3 to 63	760 - 950
FDC1000KXZXE1	3 to 66	800 - 1000

<Pipe size selection>

In the figure for pipe selection, sizes of main pipe and the pipe between the branch at the indoor side and the indoor unit are selected on the basis different from normal practice.

(1) Main pipe (branch of the outdoor unit – first branch at the indoor side)

Size of liquid pipe is different. Change the size of main pipe according to Table 4.

When the maximum length (from the outdoor unit to the furthest indoor unit) is larger than 90 m (actual length), change the size of main pipe according to Table 4.

Table 4 Main pipe size

Outdoor unit	Main pipe size (normal)		Pipe size for an actual length of 90m or longer	
	Gas pipe	Liquid pipe	Gas pipe	Liquid pipe
224	$\phi 19.05 \times t 1.0$	$\phi 12.7 \times t 0.8$	$\phi 22.22 \times t 1.0$	$\phi 12.7 \times t 0.8$
280	$\phi 22.22 \times t 1.0$		$\phi 25.4 (\phi 22.22) \times t 1.0$	
335	$\phi 28.58 \times t 1.0$	$\phi 15.88 \times t 1.0$		$\phi 31.8 \times t 1.1$ ($\phi 28.58 \times t 1.0$)
450				
500				
560				
615				
670				
735	$\phi 19.05 \times t 1.0$	$\phi 19.05 \times t 1.0$	$\phi 38.1 \times t 1.35$ ($\phi 34.92 \times t 1.2$)	$\phi 19.05 \times t 1.0$
800				
850				
900				
950				
1000				

(2) Between branch at the indoor side and indoor unit

Size of gas pipe for indoor unit with capacity larger than 112 is different. Change the size of pipe connected to indoor unit according to Table 5.

Table 5 Indoor unit connecting pipe size

Indoor unit	Capacity	Gas pipe	Liquid pipe
		15,22,28	$\phi 9.52 \times t 0.8$
36,45,56		$\phi 12.7 \times t 0.8$	
71,90		$\phi 15.88 \times t 1.0$	
112,140,160		$\phi 19.05 \times t 1.0$	$\phi 9.52 \times t 0.8$
224		$\phi 22.22 \times t 1.0$	
280		$\phi 25.4 \times t 1.0$	

(3) Refrigerant quantity

In addition to normal charge quantity for refrigerant pipes, charge quantity for the difference in capacity between the indoor and the outdoor units, and standard additional refrigerant quantity, measure and charge the additional refrigerant quantity for the installation with the difference in the elevation being over 50 m and less than 70 m.

Table 6 Additional refrigerant quantity for the installation with the difference in the elevation being over 50 m and less than 70 m

Outdoor unit	(kg)	Outdoor unit	(kg)
224	0.2	670	1.0
280	0.3	735	1.1
335	0.5	800	1.2
450	0.7	850	1.3
500	0.8	900	1.4
560	0.9	950	1.6
615	0.8	1000	1.6

(4) Microcomputer control

Setting of microcomputer control needs to be changed when the outdoor unit is installed upwards and the difference in elevation is larger than 50 m and less than 70 m. Make sure to set SW6-4 at ON position on both the master and slave units, before turning the power on.

Specification for installation with the difference between the longest and shortest piping more than 40m

When the difference between the longest and shortest piping is longer than 40 m, adjust the difference in the elevation of indoor units in a system such that it will fall in the OK range on the following graph.

When the difference in the elevation between the indoor and the outdoor units is 50 m – 70 m, the difference between the longest and shortest piping cannot exceed 40 m. Reduce it to less than 40 m.

If the refrigerant quantity over occurs when the difference between the longest and shortest piping is longer than 40 m, there is a risk that the heating capacity becomes insufficient. Take sufficient care to adjust the additional refrigerant quantity at correct value.

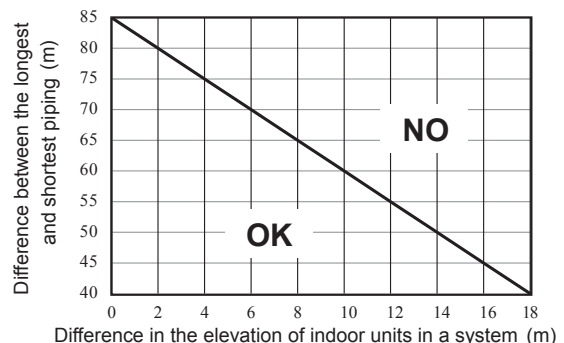

4. PIPING SYSTEM

Models FDC224KXZE1

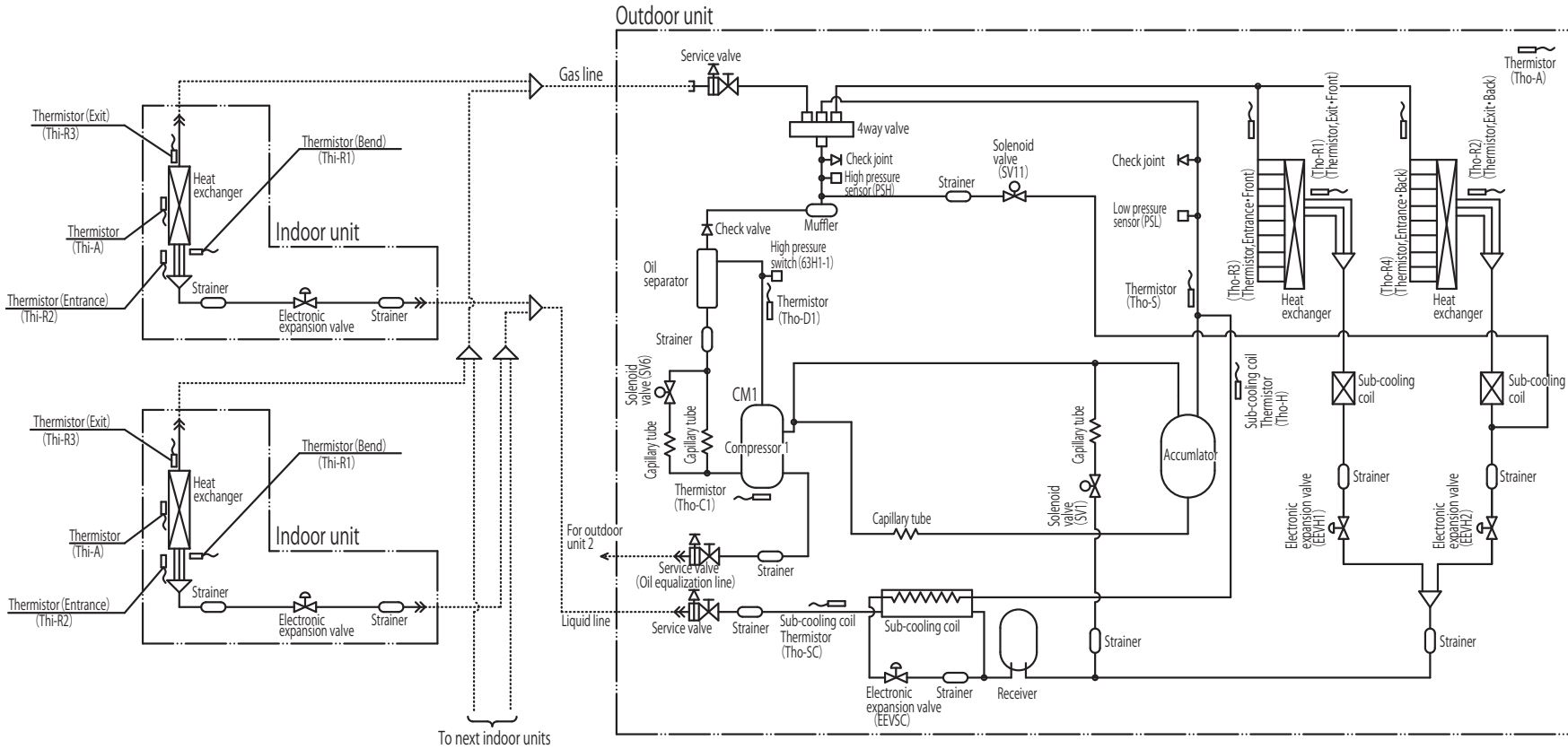

- Notes (1) Preset point of protective devices
 63H1-1 : Open 4.15MPa, Close 3.15MPa
 (For protection)
- (2) Function of thermistor
 PSH : For compressor control
 3.70 ON (MPa)
 PSL : ON 0.18MPa, OFF 0.20MPa
 (For compressor control)
 ON 0.134MPa, OFF 0.18MPa
 (For protection)

- Thi-R1, R2 : Heating operation : Indoor fan control.
 Cooling operation : Frost prevention control.
 Super heat control.
- Thi-R3 : For super heat control of cooling operation.
- Tho-D : For control of discharge pipe temperature.
- Tho-C : For control of temperature under the dome.
- Tho-S : For control of suction pipe temperature.
- Tho-R1, R2 : For control of defrosting.
- Tho-A : For control of defrosting.
- Tho-R3, R4 : Electronic expansion valve (EEVH1, 2) control of heating operation
- Tho-SC : Electronic expansion valve (EEVSC) control of cooling operation.
- Tho-H : For super heat control of sub-cooling coil.

PCB003Z862

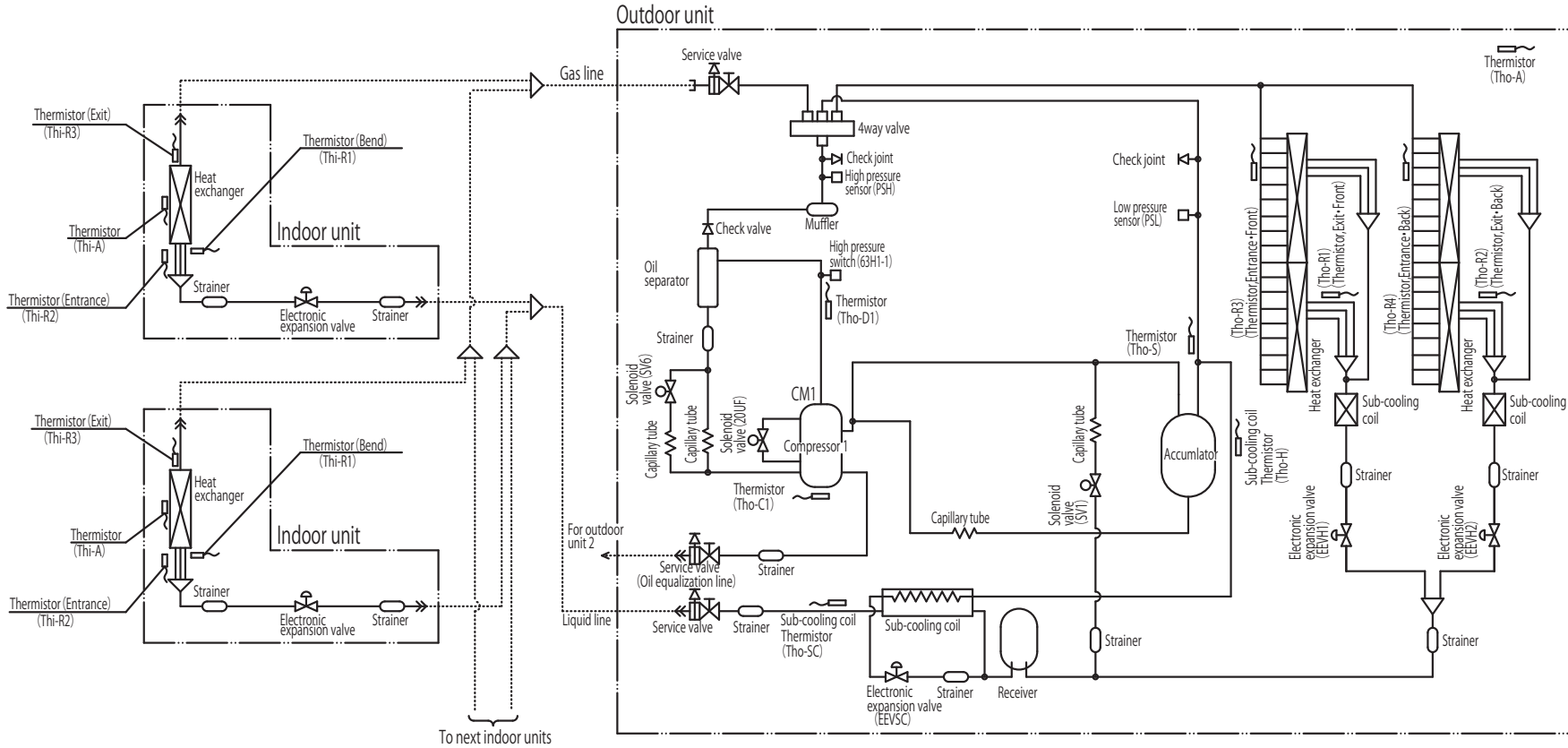

Models FDC280KXZE1, 335KXZE1

- Notes (1) Preset point of protective devices
 63H1-1 : Open 4.15MPa, Close 3.15MPa
 (For protection)
- (2) Function of thermistor
 PSH : For compressor control
 3.70 ON (MPa)
 PSL : ON 0.18MPa, OFF 0.20MPa
 (For compressor control)
 ON 0.134MPa, OFF 0.18MPa
 (For protection)

- Thi-R1, R2 : Heating operation : Indoor fan control.
 Cooling operation : Frost prevention control.
 Super heat control.
- Thi-R3 : For super heat control of cooling operation.
- Tho-D : For control of discharge pipe temperature.
- Tho-C : For control of temperature under the dome.
- Tho-S : For control of suction pipe temperature.
- Tho-R1, R2 : For control of defrosting.
- Tho-A : For control of defrosting.
- Tho-R3, R4 : Electronic expansion valve (EEVH1, 2) control of heating operation
- Tho-SC : Electronic expansion valve (EEVSC) control of cooling operation.
- Tho-H : For super heat control of sub-cooling coil.

PCB003Z863

5. SELECTION CHART

(1) Equipment selection flow

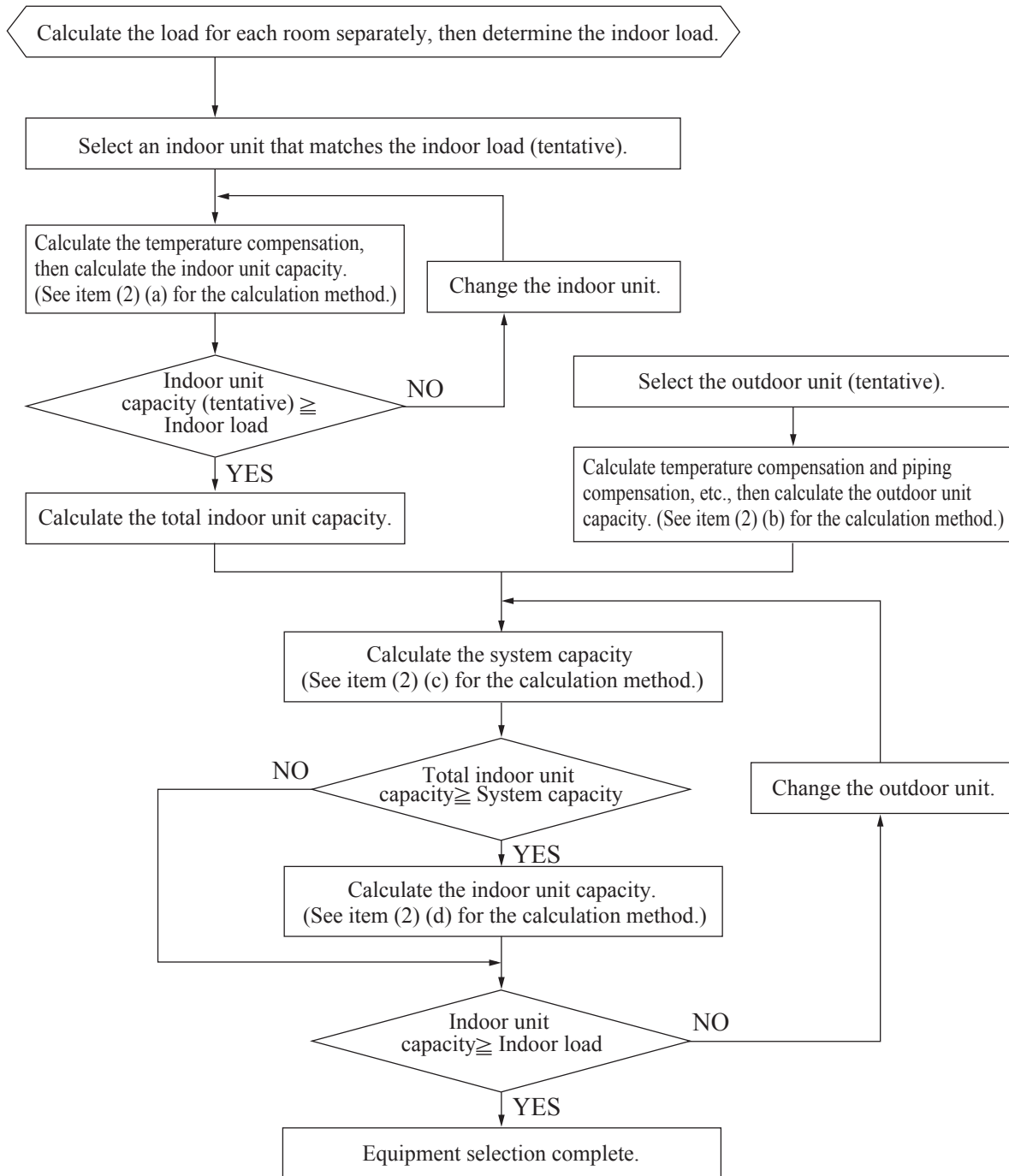

(2) Capacity calculation method**(a) Calculating the indoor unit capacity compensation**

Indoor unit capacity (cooling, heating) = Indoor unit total rated capacity
 × Capacity compensation coefficient according to temperature conditions

See item (3) (a) concerning the capacity compensation coefficient according to temperature conditions.

(b) Calculating the outdoor unit capacity compensation

Outdoor Unit Capacity (cooling, heating) = Outdoor unit rated capacity (rated capacity when 100% connected)
 × Capacity compensation coefficient according to temperature conditions
 × Capacity compensation coefficient according to piping length
 × Capacity compensation coefficient according to height difference
 × Correction of heating capacity in relation to the frost on the outdoor unit heat exchanger
 × Capacity compensation coefficient according to indoor unit connection capacity

- ① See item (3) (a) concerning the capacity compensation coefficient according to temperature conditions.
- ② See item (3) (b) concerning the capacity compensation coefficient according to piping length.
- ③ See item (3) (c) concerning the capacity compensation coefficient according to height difference. This compensation should be carried out only in cases where the outdoor unit is lower during cooling and higher during heating.
- ④ See item (3) (d) correction of heating capacity in relation to the frost on the outdoor unit heat exchanger. This compensation should be carried out only when calculating the heating capacity.
- ⑤ See item (3) (e) concerning the capacity compensation coefficient according to indoor unit connected capacity. This compensation should be carried out only in cases where the indoor unit total capacity is 100% or higher.

(c) Calculating system capacity

Compare the capacities determined in items (a) and (b) above and let the smaller value be the system capacity (cooling, heating).

- ① In cases where indoor unit total capacity (cooling, heating) > outdoor unit capacity (cooling, heating)
 System capacity (cooling, heating) = Outdoor unit capacity (cooling, heating)
- ② In cases where indoor unit total capacity (cooling, heating) < outdoor unit capacity (cooling, heating)
 System capacity (cooling, heating) = Indoor unit capacity (cooling, heating)

(d) Calculating indoor unit capacity [item (c) ① only]

Indoor unit capacity (cooling, heating) = System capacity (cooling, heating)
 × [(Indoor unit capacity) / (Indoor unit total capacity)]

Capacity calculation examples**Example 1****Cooling (when the indoor unit connected total capacity is less than 100%)**

- Outdoor unit FDC450KXZXE1 FDC224KXZXE1 × 2 units
- Indoor unit FDT56KXE6F 7 units
- Piping length 60 m (Equivalent length)
- Indoor, outdoor unit height difference 15 m (Outdoor unit is lower)
- Temperature conditions Outdoor temperature: 33°C DB
- Temperature conditions Indoor temperature: 19°C WB

<Indoor unit total cooling capacity>: Item (2) (a) calculation.

- Indoor unit rated cooling capacity: 5.6 kW
- Capacity compensation coefficient according to temperature conditions:
 1.02 (Calculated according to Indoor 19°C WB / Outdoor 33°C DB); (See page 23)
 Indoor unit cooling capacity: 5.6 kW × 1.02 = 5.7 kW
- Indoor unit total cooling capacity calculation;
 indoor unit total cooling capacity: 5.7 kW × 7 units = 39.9 kW

<Outdoor unit maximum cooling capacity> : Item (2) (b) calculation

- Outdoor unit rated cooling capacity: 45.0 kW
- Capacity compensation coefficient according to temperature conditions:
 1.02 (Calculated according to Indoor 19°C WB / Outdoor 33°C DB); (See page 23)
 Outdoor unit cooling capacity: 45.0 kW × 1.02 = 45.9 kW
- Capacity compensation coefficient according to piping length: 0.94 (calculated according to 60 m length); (See page 25)
 45.9 kW × 0.94 = 43.1 kW

- Capacity compensation coefficient according to height difference: 0.97 (calculated according to 15 m difference); (See page 27)
 $43.1 \text{ kW} \times 0.97 = \underline{41.8 \text{ kW}}$
- Capacity compensation coefficient according to indoor unit connected total capacity: $1.0 \leftarrow (56 \times 7) / 450 < 100\%$
 No compensation

<System cooling capacity>: Item (2) (c) calculation

Compare the indoor unit total cooling capacity and the outdoor unit maximum cooling capacity. The smaller value is the actual system cooling capacity.

- Indoor unit total cooling capacity: 39.9 kW
 - Outdoor unit maximum cooling capacity: 41.8 kW
- ⇒ System cooling capacity: 39.9 kW

<Indoor unit capacity compensation> No compensation (5.7 kW)

Example 2

Cooling (when the indoor unit connected total capacity is 100% or higher)

- Outdoor unit FDC450KXZXE1 FDC224KXZXE1 × 2 units
- Indoor unit FDT56KXE6F 10 units
- Piping length 60 m (Equivalent length)
- Indoor, outdoor unit height difference 15 m (Outdoor unit is higher)
- Temperature conditions Outdoor temperature: 35°C DB
- Temperature conditions Indoor temperature: 18°C WB

<Indoor unit total cooling capacity>: Item (2) (a) calculation.

- Indoor unit rated cooling capacity: 5.6 kW
- Capacity compensation coefficient according to temperature conditions:
 0.95 (Calculated according to Indoor 18°C WB / Outdoor 35°C DB); (See page 23)
 Indoor unit cooling capacity: $5.6 \text{ kW} \times 0.95 = 5.3 \text{ kW}$
- Indoor unit total cooling capacity calculation;
 indoor unit total cooling capacity: $5.3 \text{ kW} \times 10 \text{ units} = \underline{53.0 \text{ kW}}$

<Outdoor unit maximum cooling capacity> : Item (2) (b) calculation

- Outdoor unit rated cooling capacity: 45.0 kW
- Capacity compensation coefficient according to temperature conditions:
 0.95 (Calculated according to Indoor 18°C WB / Outdoor 35°C DB); (See page 23)
 Outdoor unit cooling capacity: $45.0 \text{ kW} \times 0.95 = 42.8 \text{ kW}$
- Capacity compensation coefficient according to piping length: 0.94 (calculated according to 60 m length); (See page 25)
 $42.8 \text{ kW} \times 0.94 = 40.2 \text{ kW}$
- Capacity compensation coefficient according to height difference: 1.0 (the outdoor unit is higher during cooling)
 No compensation
- Capacity compensation coefficient according to indoor unit connected total capacity: $1.05 \leftarrow (56 \times 10) / 450 = 124\%$ (See page 29)
 $40.2 \text{ kW} \times 1.05 = \underline{42.2 \text{ kW}}$

<System cooling capacity>: Item (2) (c) calculation

Compare the indoor unit total cooling capacity and the outdoor unit maximum cooling capacity. The smaller value is the actual system cooling capacity.

- Indoor unit total cooling capacity : 53.0 kW
 - Outdoor unit maximum cooling capacity : 42.2 kW
- ⇒ System cooling capacity: 42.2 kW

<Indoor unit cooling capacity Compensation>: Item (2) (d) calculation.

$$\frac{42.2 \text{ kW} \times 5.3 \text{ kW}}{53.0 \text{ kW}} = \underline{4.2 \text{ kW}}$$

Example 3

Heating (when the indoor unit connected total capacity is 100% or higher)

- Outdoor unit FDC450KXZXE1 FDC224KXZXE1 × 2 units
- Indoor unit FDT56KXE6F 10 units
- Piping length 60 m (Equivalent length)
- Indoor, outdoor unit height difference 20 m (Outdoor unit is higher)
- Temperature conditions Outdoor temperature: 6°C WB
- Temperature conditions Indoor temperature: 19°C DB

<Indoor unit total heating capacity>: Item (2) (a) calculation.

- Indoor unit rated heating capacity: 6.3 kW
- Capacity compensation coefficient according to temperature conditions:
 1.04 (Calculated according to Outdoor 6°C WB / Indoor 19°C DB); (See page 24)
 Indoor unit heating capacity: $6.3 \text{ kW} \times 1.04 = 6.6 \text{ kW}$
- Indoor unit total heating capacity calculation;
 indoor unit total heating capacity: $6.6 \text{ kW} \times 10 \text{ units} = \underline{66.0 \text{ kW}}$

<Outdoor unit maximum heating capacity> : Item (2) (b) calculation

- Outdoor unit rated heating capacity: 50.0 kW
- Capacity compensation coefficient according to temperature conditions:
1.04 (Calculated according to Outdoor 6°C WB / Indoor 19°C DB); (See page 24)
Outdoor unit heating capacity: 50.0 kW × 1.04 = 52.0 kW
- Capacity compensation coefficient according to piping length: 0.982 (calculated according to 60 m length); (See page 27)
52.0 kW × 0.982 = 51.0 kW
- Capacity compensation coefficient according to height difference: 0.96 (calculated according to 20 m difference); (See page 27)
51.0 kW × 0.96 = 49.0 kW
- Correction of heating capacity in relation to the frost on the outdoor unit heat exchanger:
1.0 (calculated according to 6°C WB); (See page 27)
49.0 kW × 1.0 = 49.0 kW.
- Capacity compensation coefficient according to indoor unit connected total capacity: 1.01 ← (56 × 10) / 450 = 124% (See page 29)
49.0 kW × 1.01 = 49.5 kW.

<System heating capacity> : Item (2) (c) calculation

Compare the indoor unit total heating capacity and the outdoor unit maximum heating capacity. The smaller value is the actual system heating capacity.

- Indoor unit total heating capacity : 66.0 kW ⇒ System heating capacity: 49.5 kW
- Outdoor unit maximum heating capacity : 49.5 kW

<Indoor unit heating capacity compensation> : Item (2) (d) calculation

$$\frac{49.5 \text{ kW} \times 6.6 \text{ kW}}{66.0 \text{ kW}} = 5.0 \text{ kW}$$

(3) Capacity compensation coefficient

(a) Capacity compensation coefficient and power consumption compensation coefficient according to indoor and outdoor temperature conditions.

1) Capacity compensation coefficient

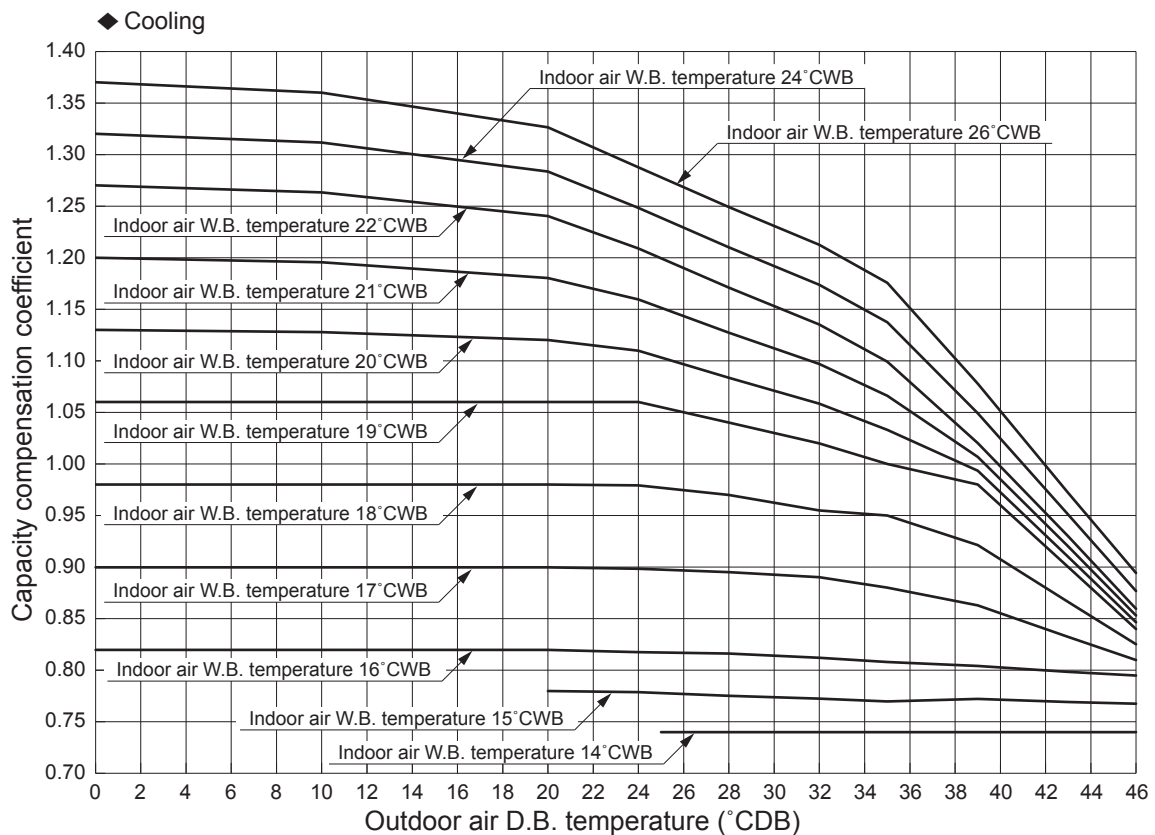

Note (1) The above-mentioned table shows a typical condition among conditions to occur via controlling an air-conditioning equipment.
 (2) When performing the cooling operation with the outdoor air temperature being -5°C or under, a windbreak fence must be installed.

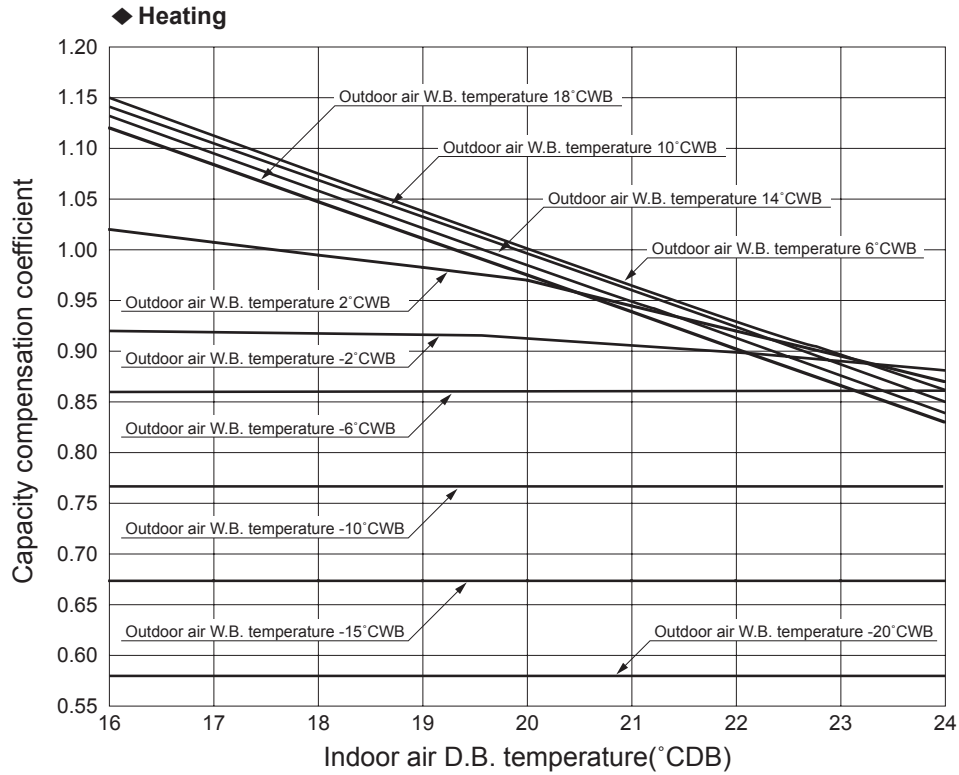

Note (1) The above-mentioned table shows a typical condition among conditions to occur via controlling an air-conditioning equipment.

2) Power consumption correction factor

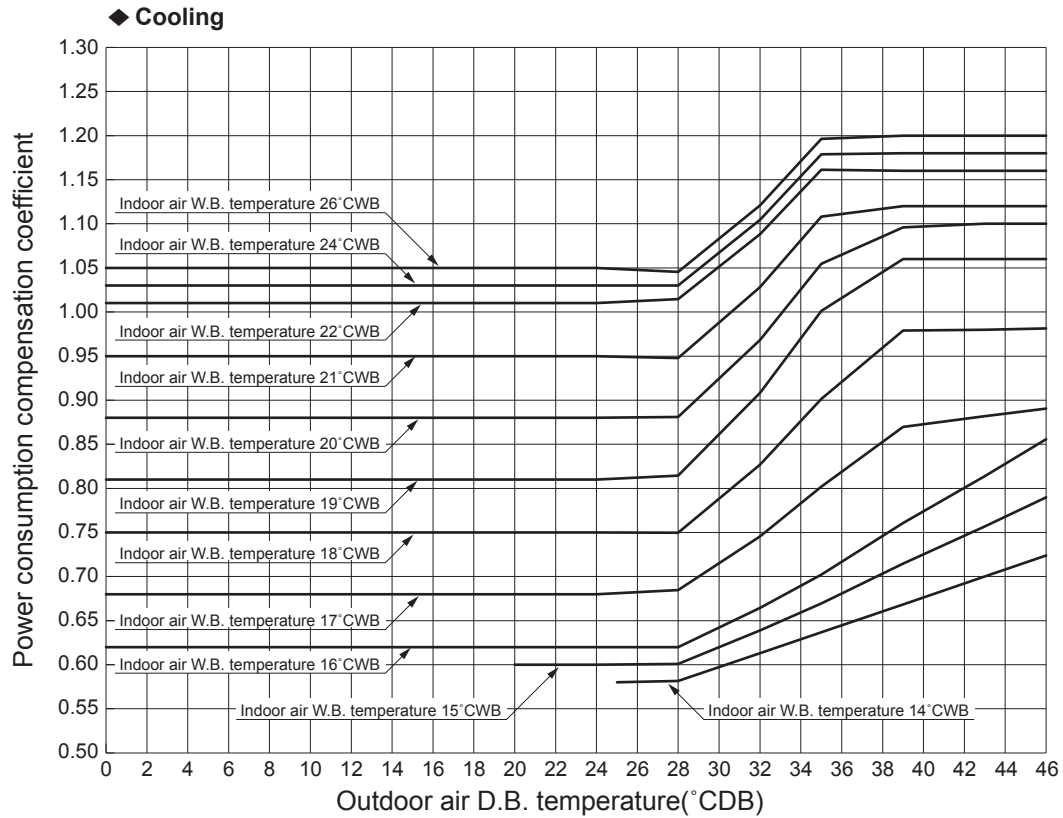

Note (1) The above-mentioned table shows a typical condition among conditions to occur via controlling an air-conditioning equipment.

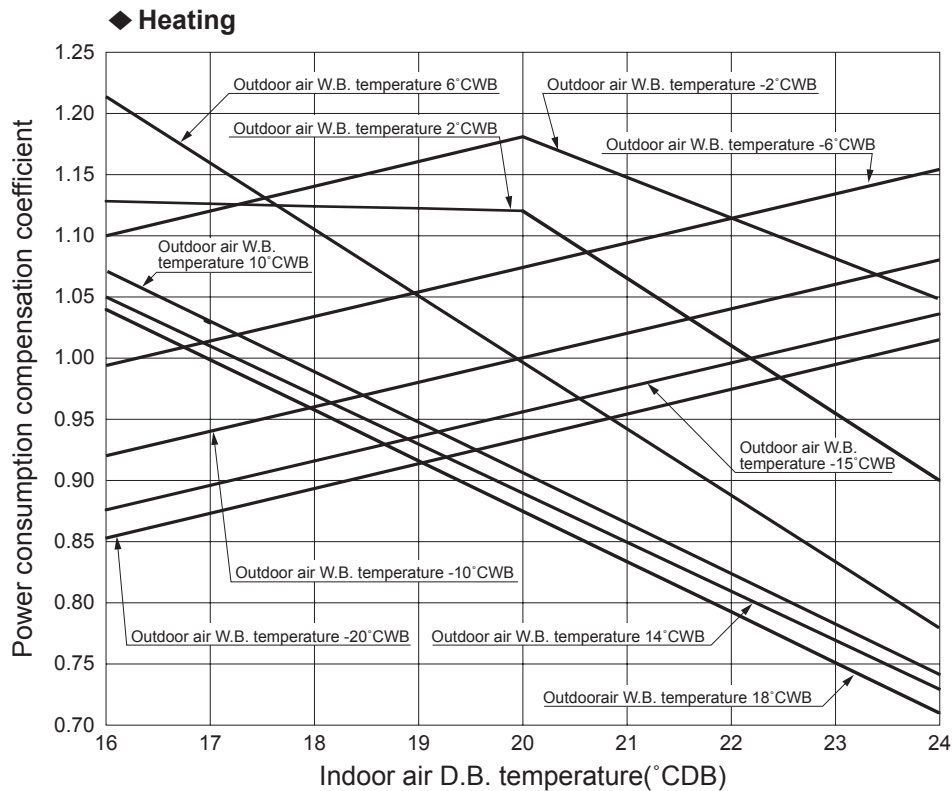

Note (1) The above-mentioned table shows a typical condition among conditions to occur via controlling an air-conditioning equipment.

(b) Correction of cooling and heating capacity in relation to one way length of refrigerant piping.

(Note) This table is for reference only. If the refrigerant piping one way equivalent after the first branch is extended longer than 40 m, it could drop further by about 10% in the worst case.

1) Cooling

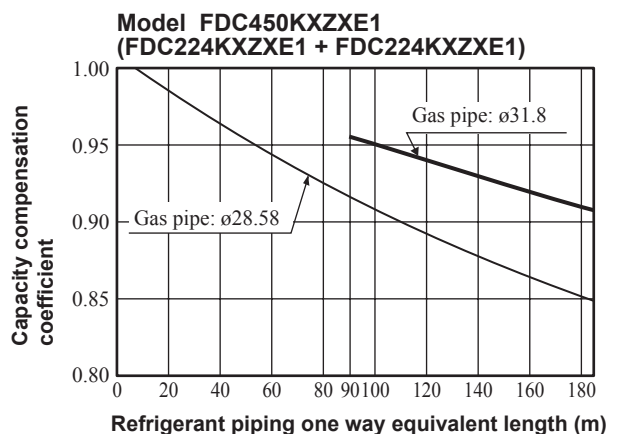
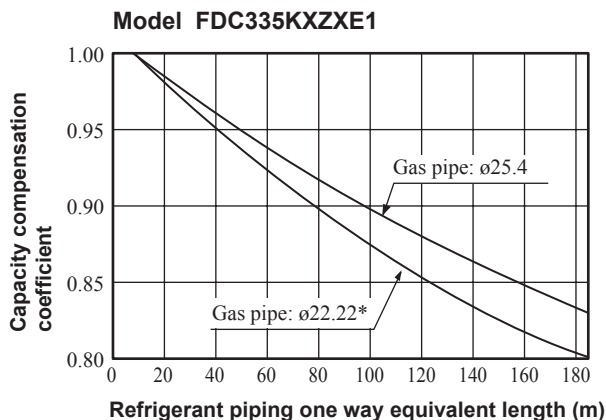
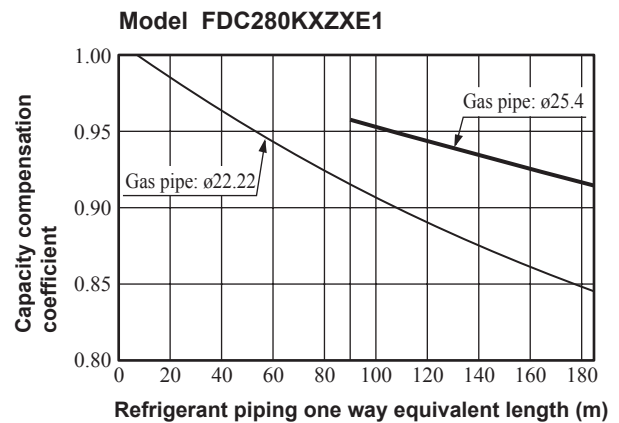
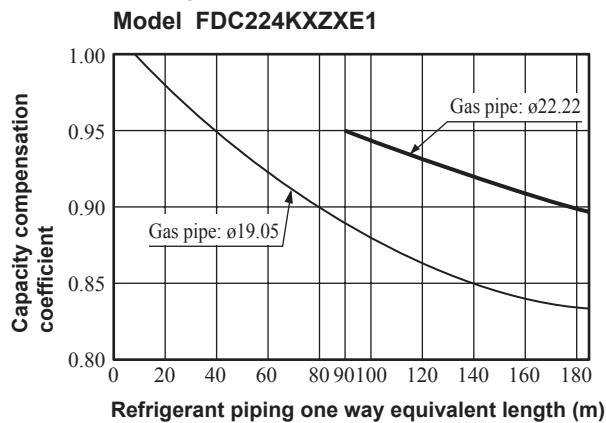

Note (1) Parts with the * mark show the piping size in case used in Europe.

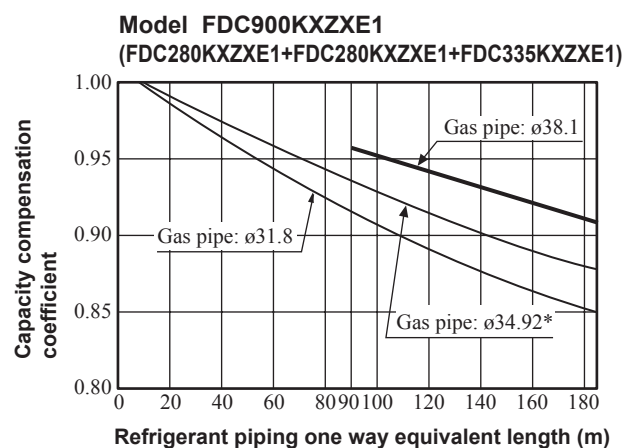
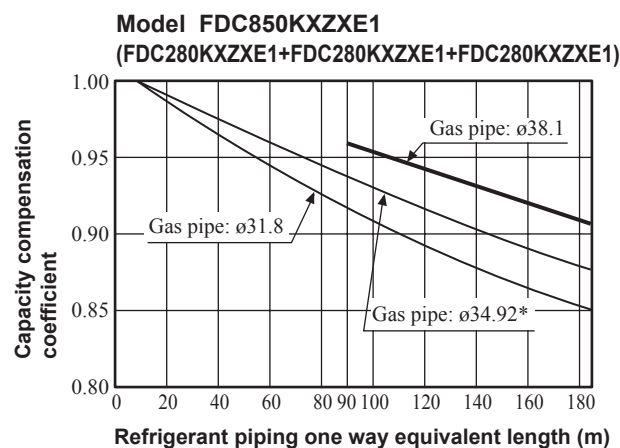
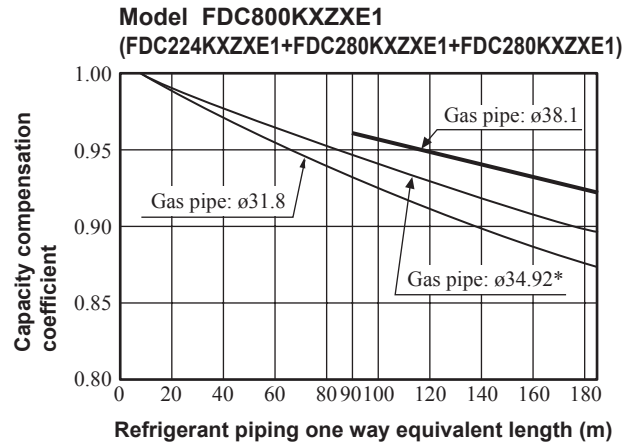
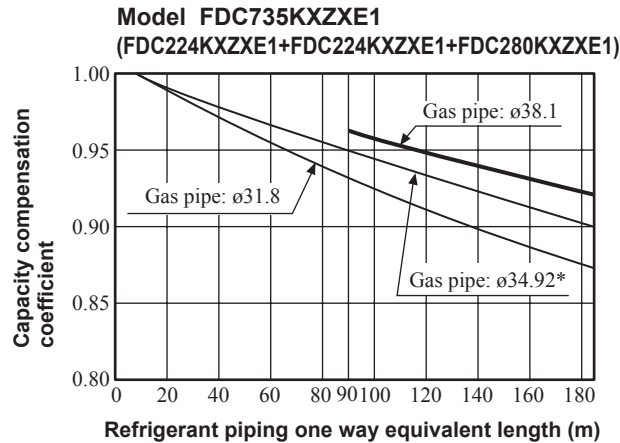
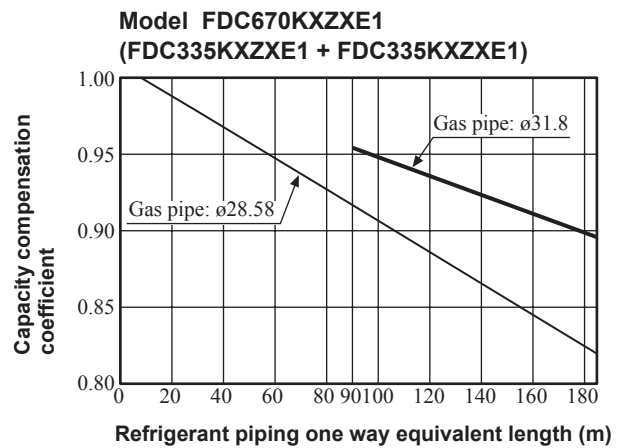
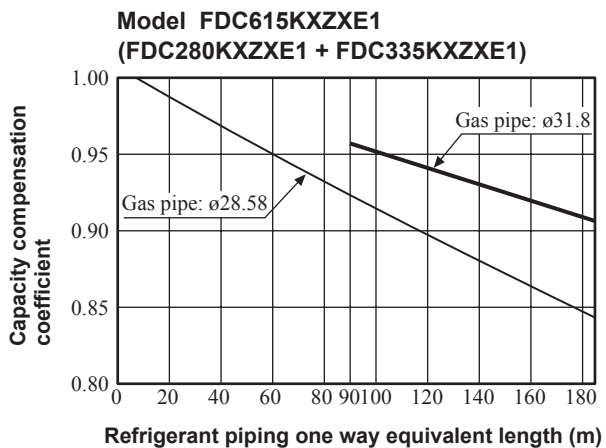
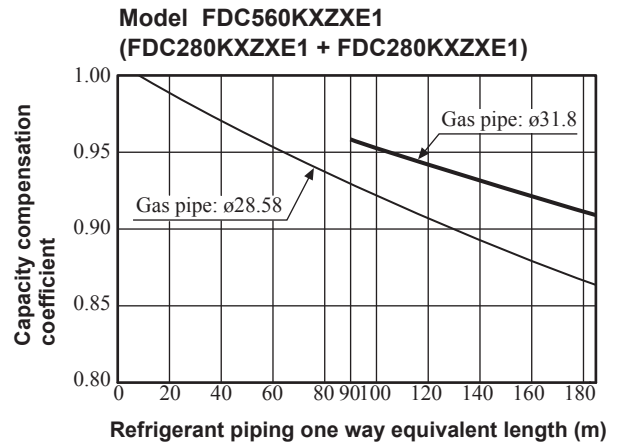
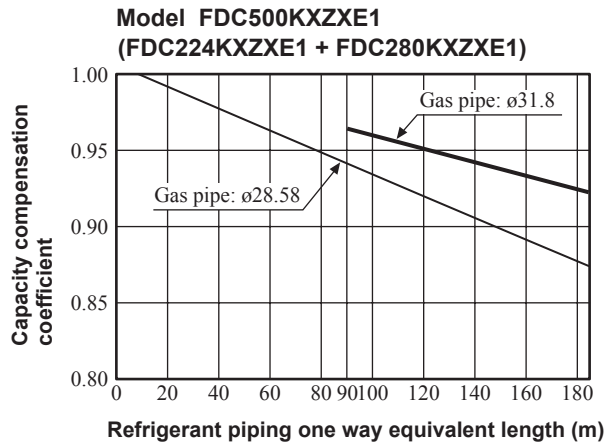

Note (1) Parts with the * mark show the piping size in case used in Europe.

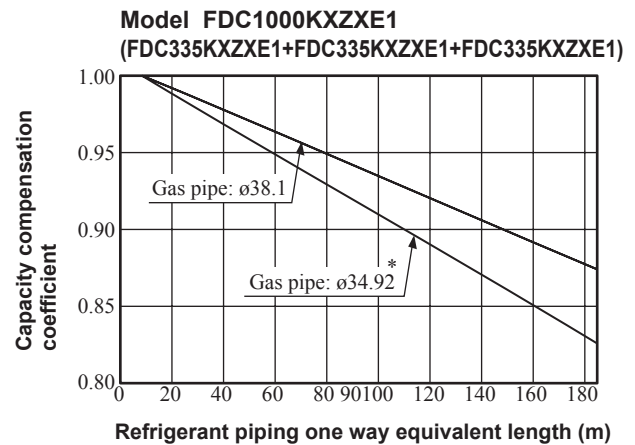
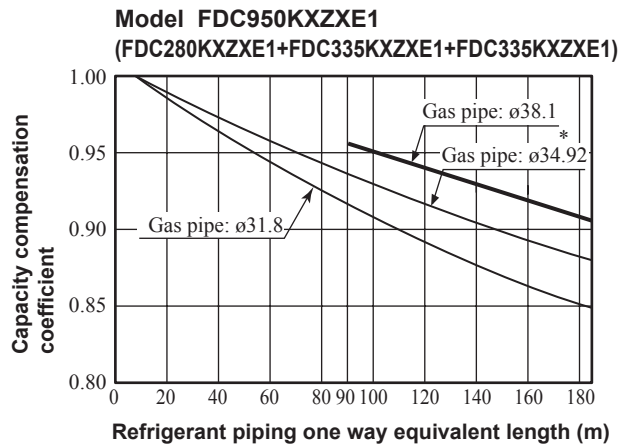

Note (1) Parts with the * mark show the piping size in case used in Europe.

2) Heating

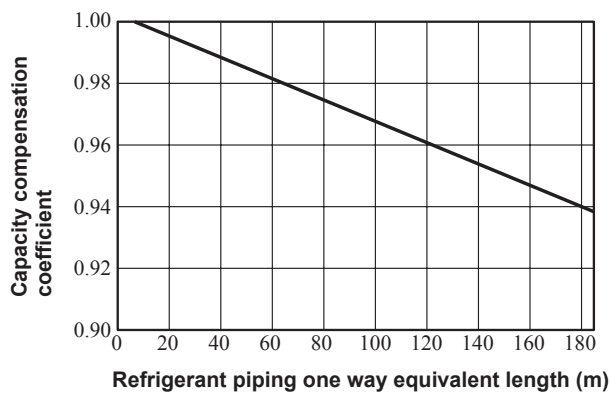

Note (1) Equivalent piping length can be obtained by calculating as follows.

$$\text{Equivalent piping length} = \text{Real gas piping length} + \text{Number of bends in gas piping} \times \text{Equivalent piping length of bends.}$$

Equivalent length of each joint

Unit : m/one part

Gas piping size	φ 15.88	φ 19.05	φ 22.22	φ 25.4	φ 28.58	φ 31.8	φ 34.92	φ 38.1
Joint (90° elbow)	0.25	0.30	0.35	0.40	0.45	0.55	0.60	0.65

(c) When the outdoor unit is located at a lower height than the indoor unit in cooling operation and when the outdoor unit is located at a higher height than the indoor unit in heating operation, the following values should be subtracted from the values in the above table.

Height difference between the indoor unit and outdoor unit in the vertical height difference	5 m	10 m	15 m	20 m	25 m	30 m	35 m
Adjustment coefficient	0.99	0.98	0.97	0.96	0.95	0.94	0.93
Height difference between the indoor unit and outdoor unit in the vertical height difference	40 m	45 m	50 m	55 m	60 m	65 m	70 m
Adjustment coefficient	0.92	0.91	0.90	0.89	0.88	0.87	0.86

(d) Correction of heating capacity in relation to the frost on the outdoor unit heat exchanger

Air inlet temperature of outdoor unit in °C WB	-20	-15	-13	-11	-9	-7	-5	-3	-1	1	3	5 or more
Adjustment coefficient	0.96	0.96	0.96	0.95	0.94	0.93	0.91	0.88	0.86	0.87	0.92	1

The correction factors will change drastically according to weather conditions. So necessary adjustment should be made empirically according to the weather data of the particular area.

(e) The capacity compensation coefficient and power consumption compensation coefficient vary according to the total capacity of concurrently operating indoor units, as shown below.

(Note) This table shows typical values.

Model FDC224KXZXE1

◆ Capacity compensation coefficient
Cooling

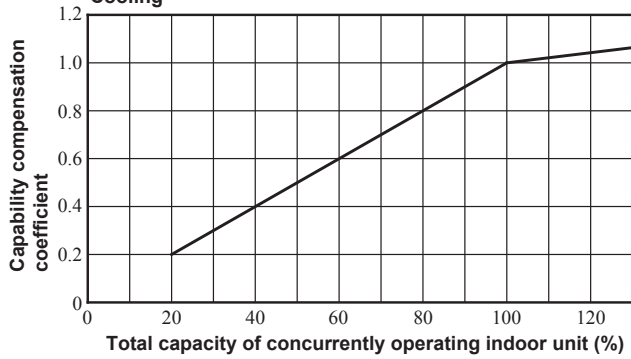

Heating

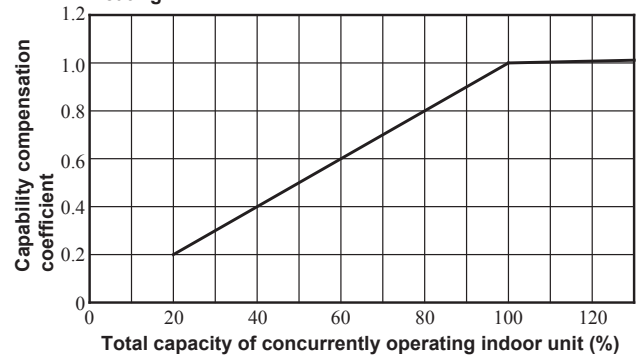

◆ Power consumption compensation coefficient
Cooling

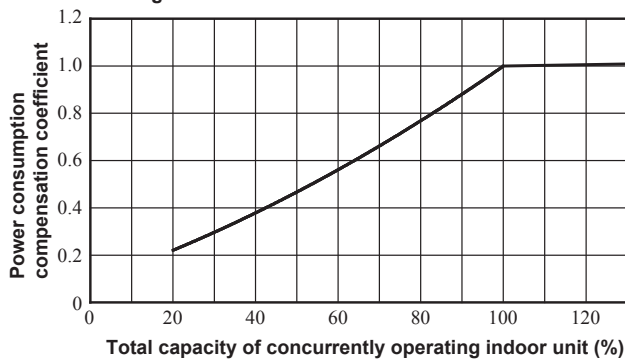

Heating

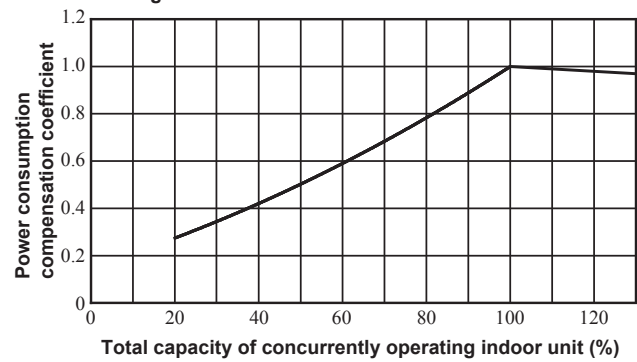

Model FDC280KXZXE1

◆ Capacity compensation coefficient
Cooling

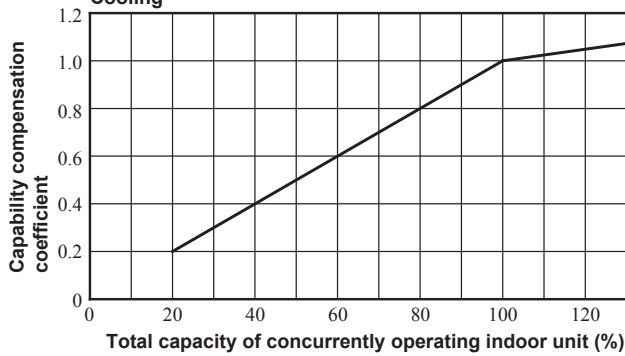

Heating

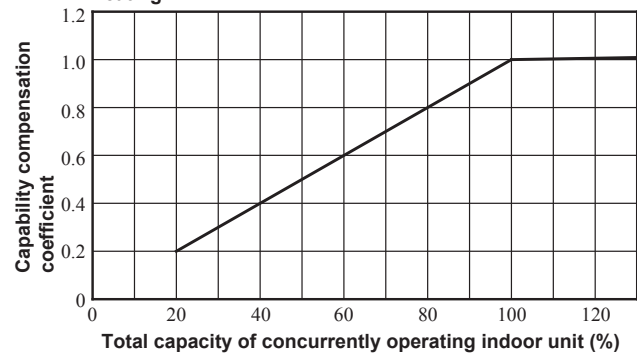

◆ Power consumption compensation coefficient
Cooling

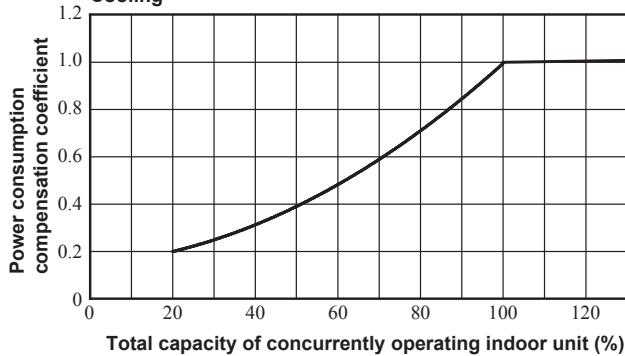

Heating

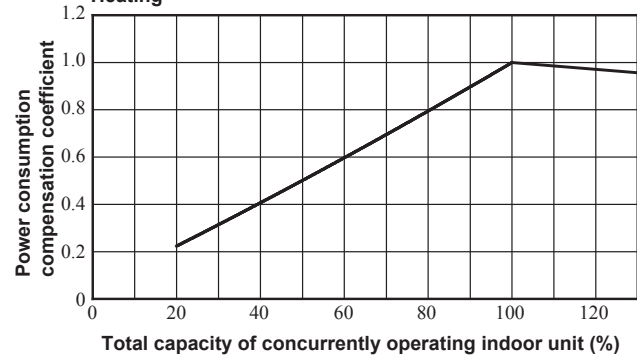

Model FDC335KXZE1

◆ **Capability compensation coefficient**
Cooling

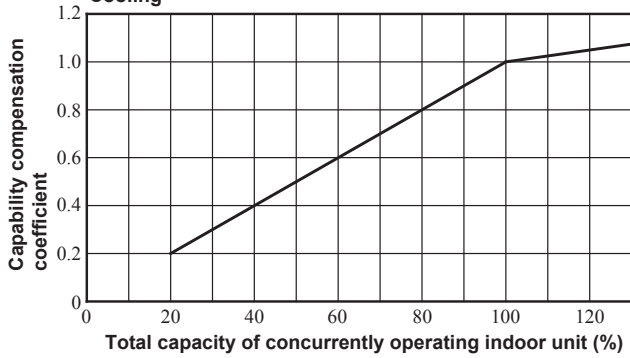

Heating

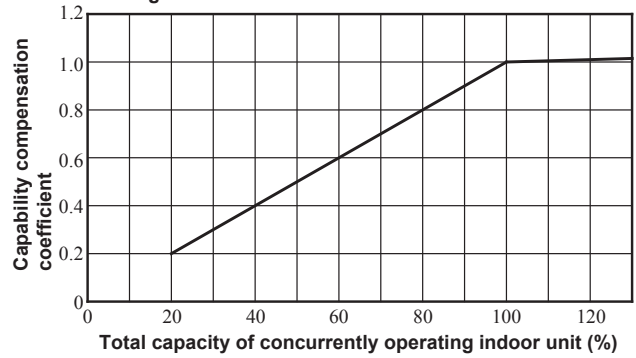

◆ **Power consumption compensation coefficient**
Cooling

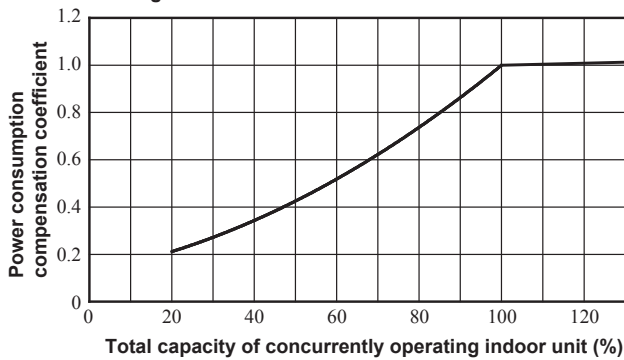

Heating

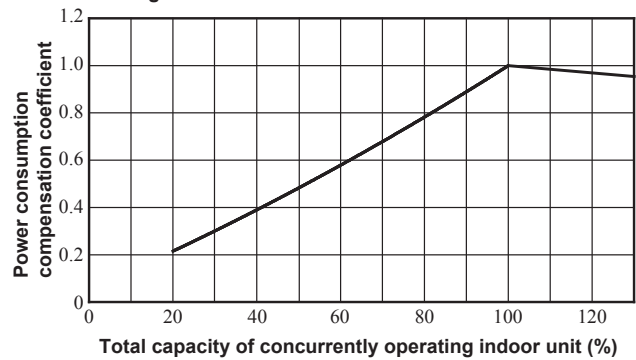

Model FDC450KXZE1

◆ **Capability compensation coefficient**
Cooling

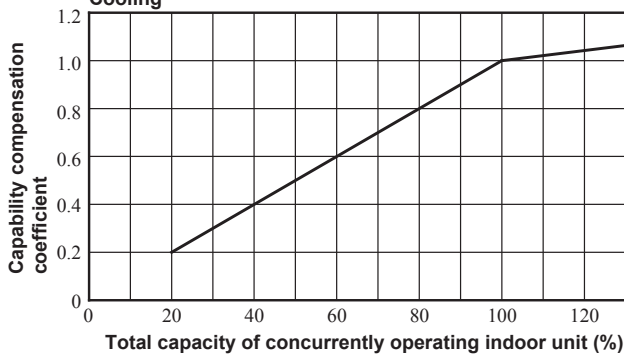

Heating

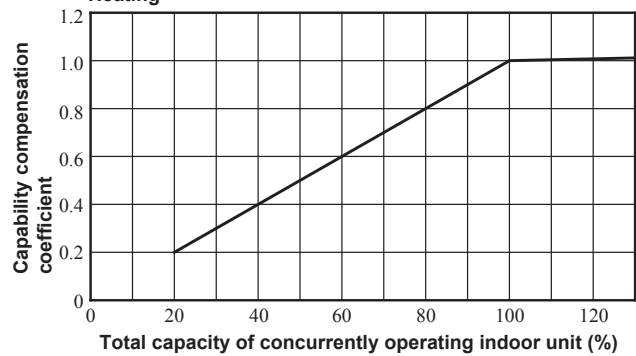

◆ **Power consumption compensation coefficient**
Cooling

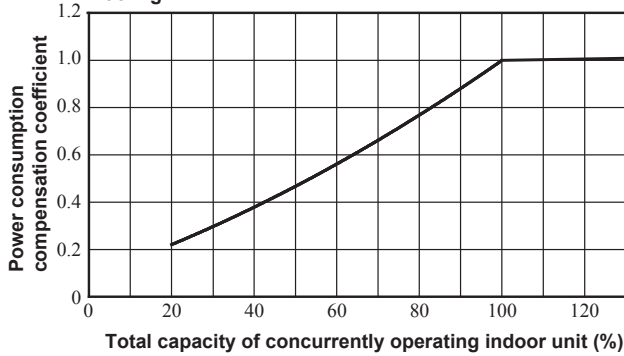

Heating

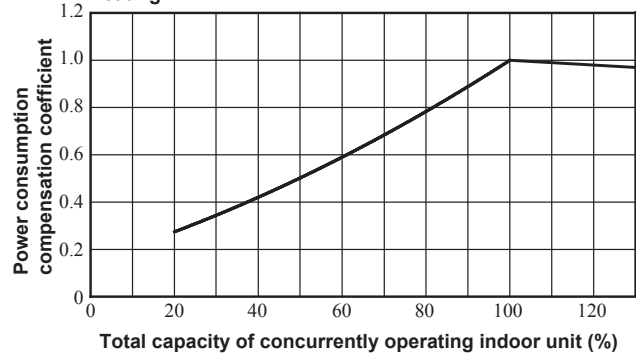

Model FDC500KXZE1

◆ **Capability compensation coefficient**
Cooling

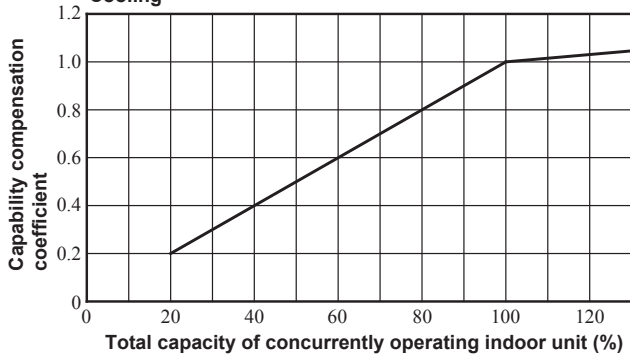

Heating

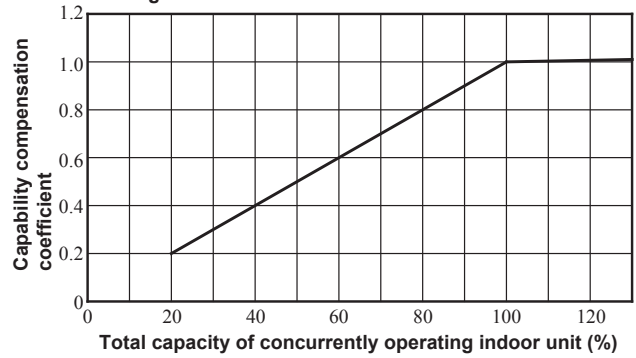

◆ **Power consumption compensation coefficient**
Cooling

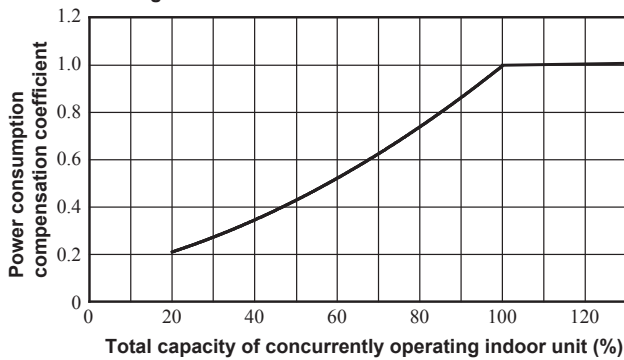

Heating

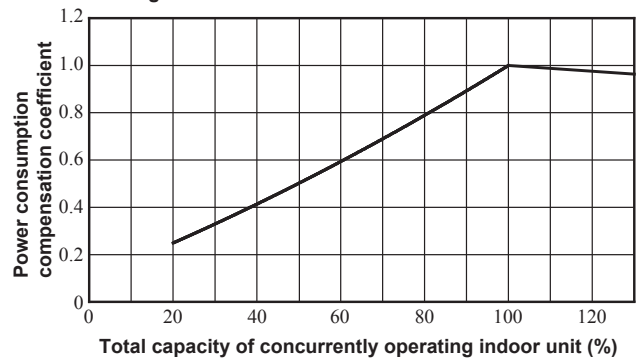

Model FDC560KXZE1

◆ **Capability compensation coefficient**
Cooling

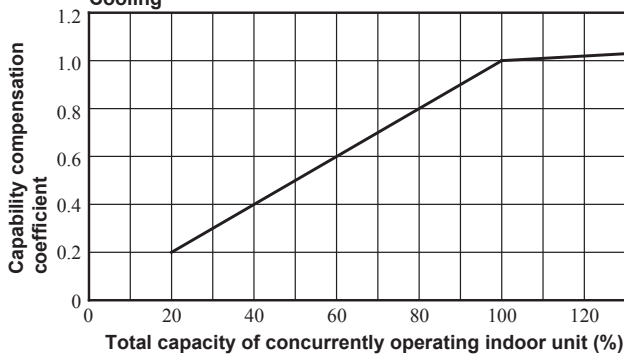

Heating

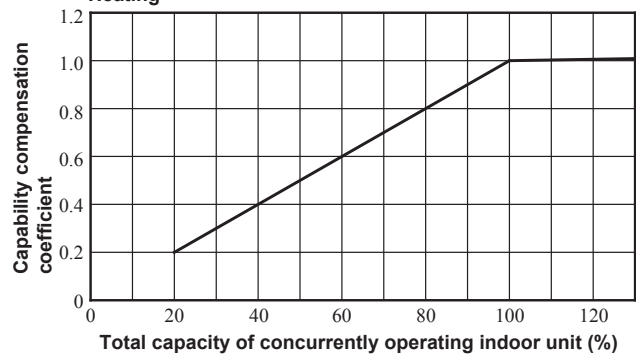

◆ **Power consumption compensation coefficient**
Cooling

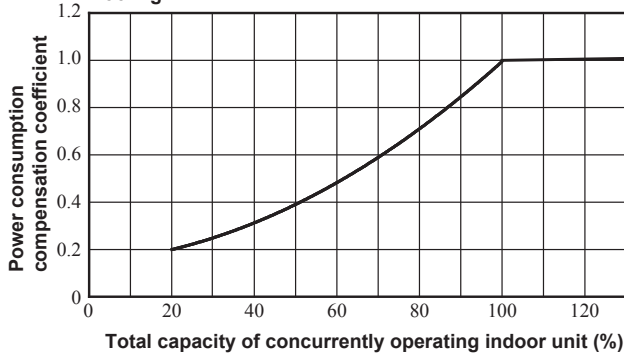

Heating

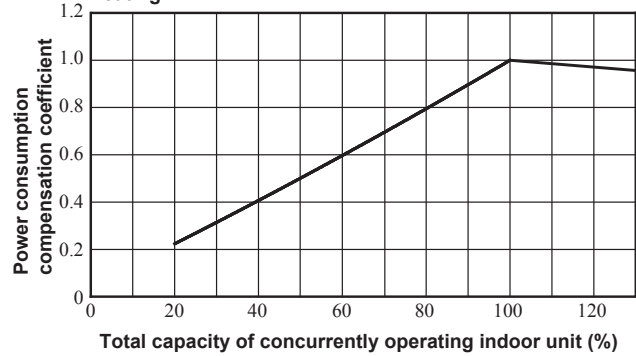

Model FDC615KXZXE1

◆ **Capability compensation coefficient**
Cooling

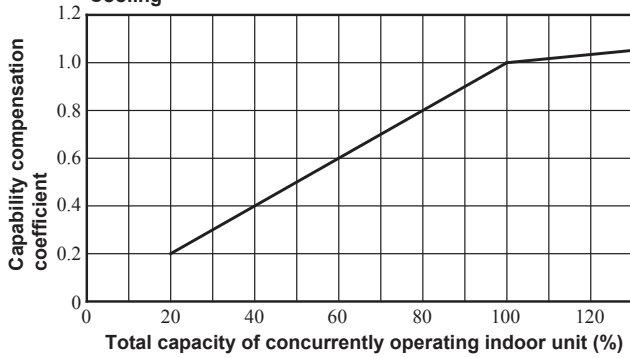

Heating

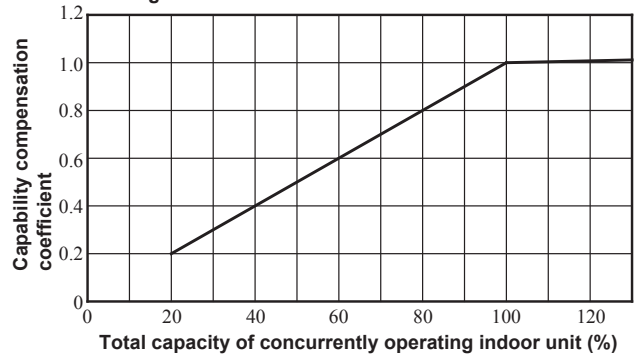

◆ **Power consumption compensation coefficient**
Cooling

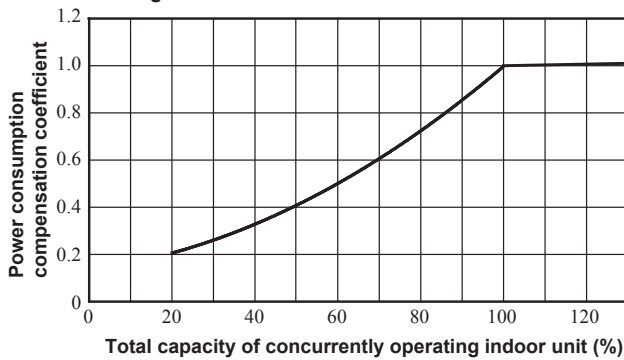

Heating

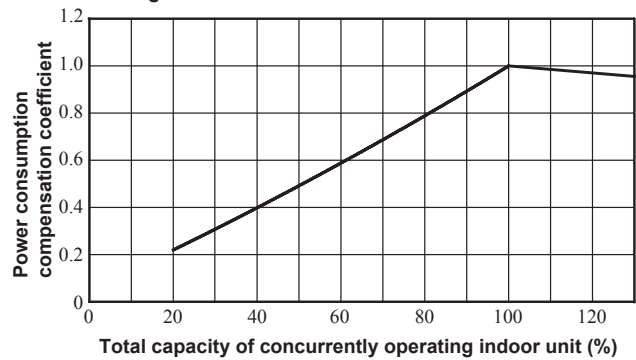

Model FDC670KXZXE1

◆ **Capability compensation coefficient**
Cooling

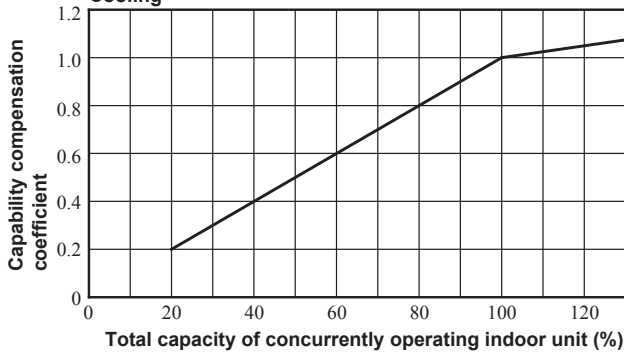

Heating

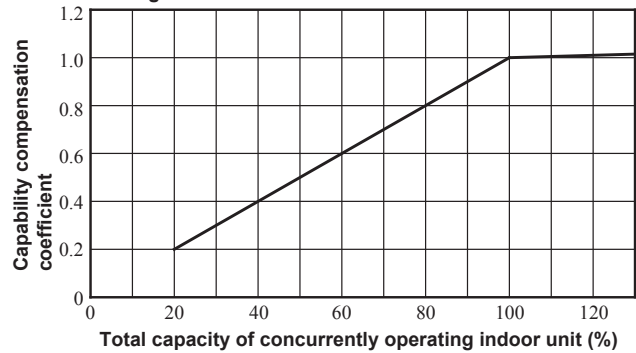

◆ **Power consumption compensation coefficient**
Cooling

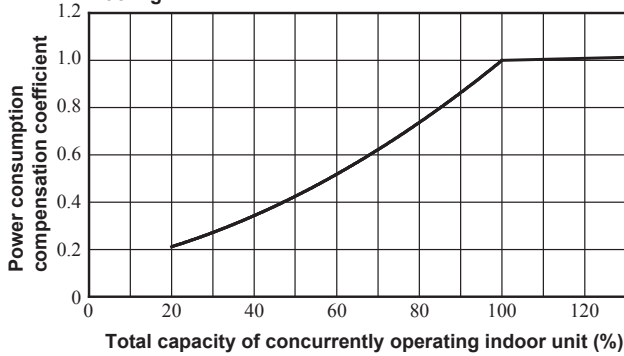

Heating

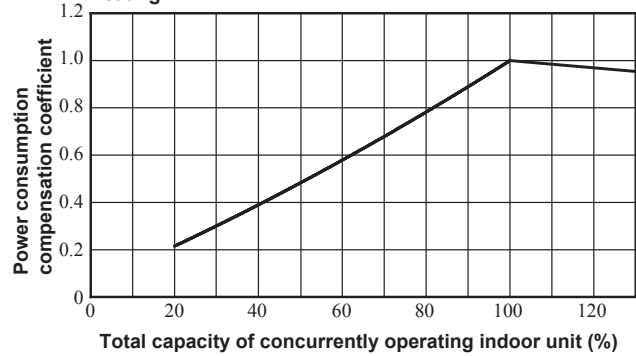

Model FDC735KXZXE1

◆ Capability compensation coefficient

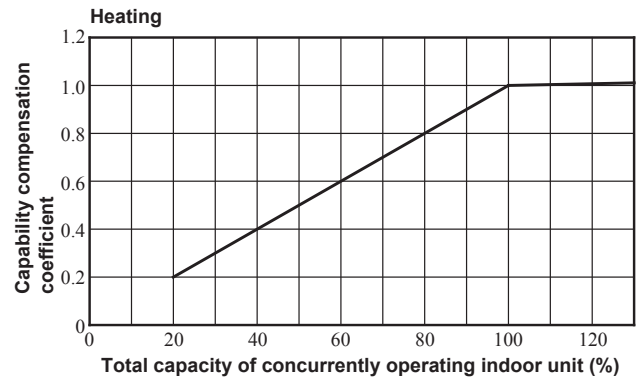
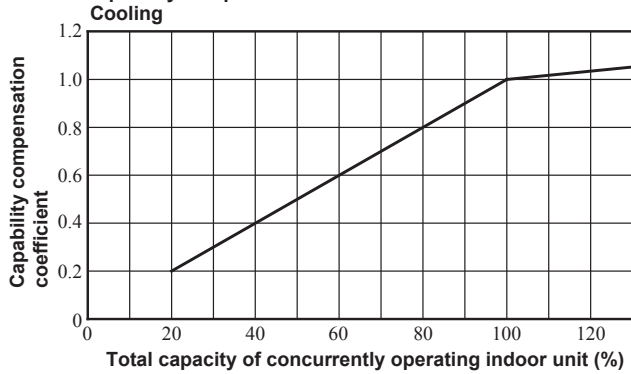

◆ Power consumption compensation coefficient

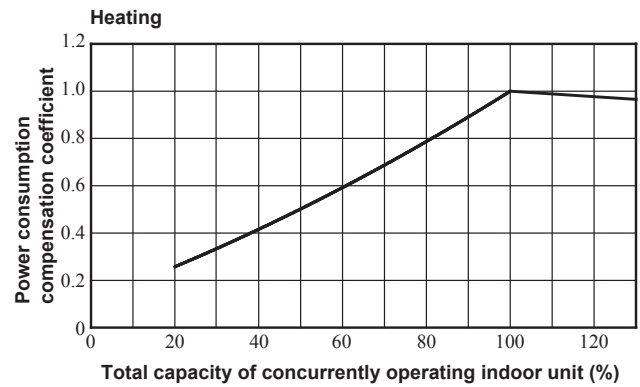
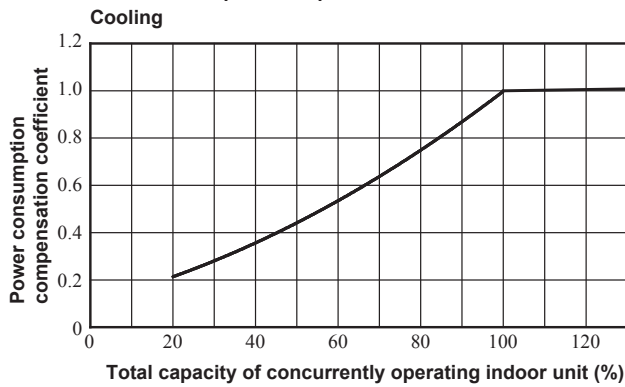

Model FDC800KXZXE1

◆ Capability compensation coefficient

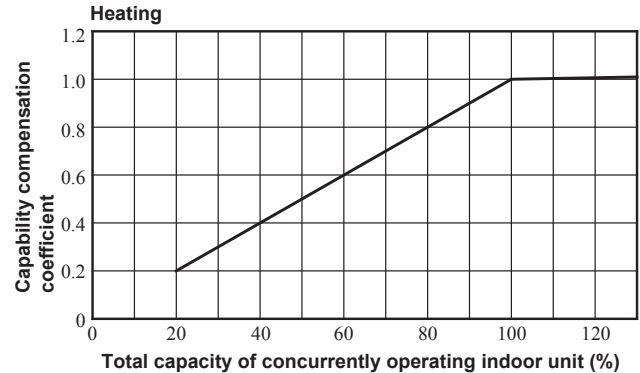
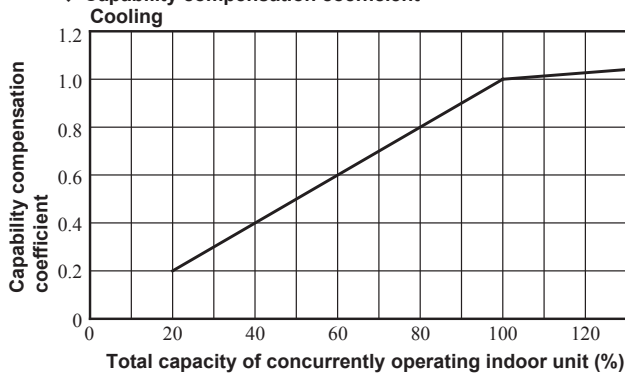

◆ Power consumption compensation coefficient

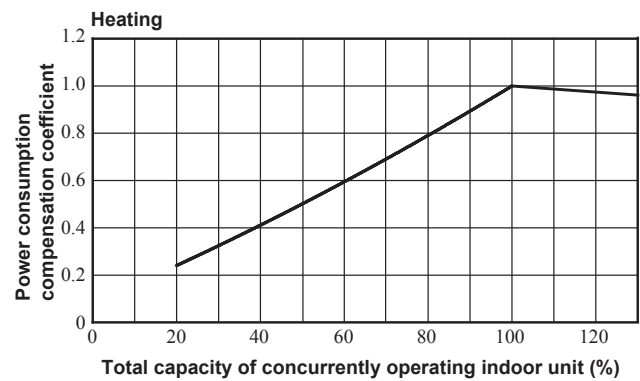
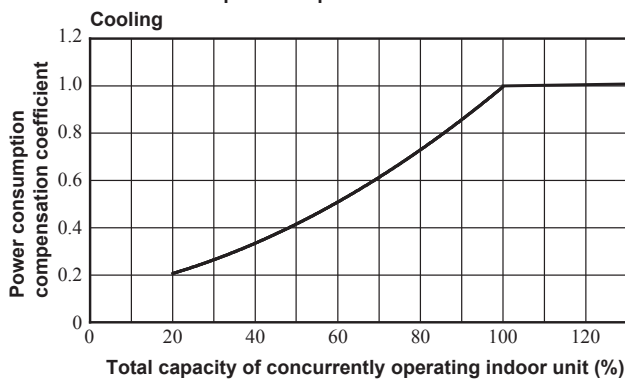

Model FDC850KXZXE1

◆ Capability compensation coefficient

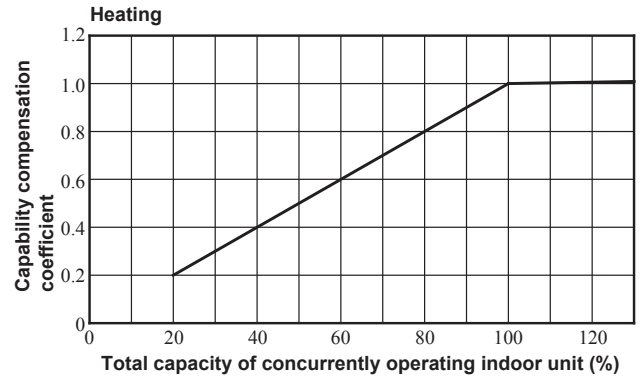
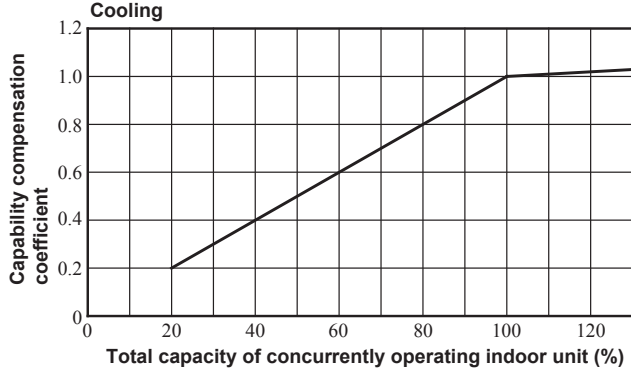

◆ Power consumption compensation coefficient

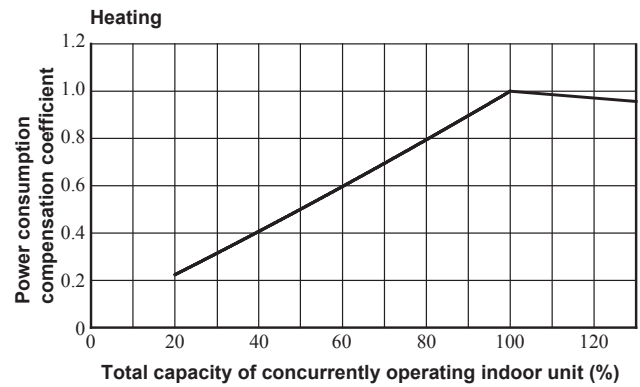
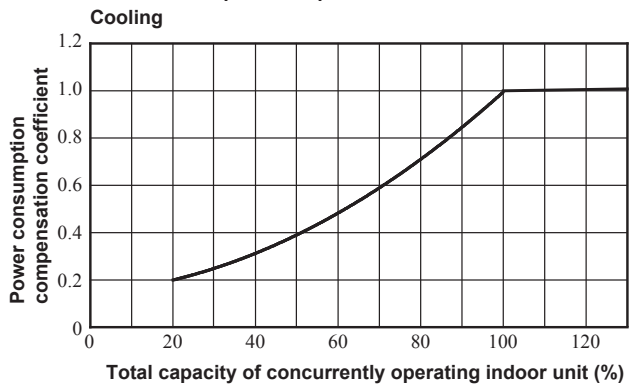

Model FDC900KXZXE1

◆ Capability compensation coefficient

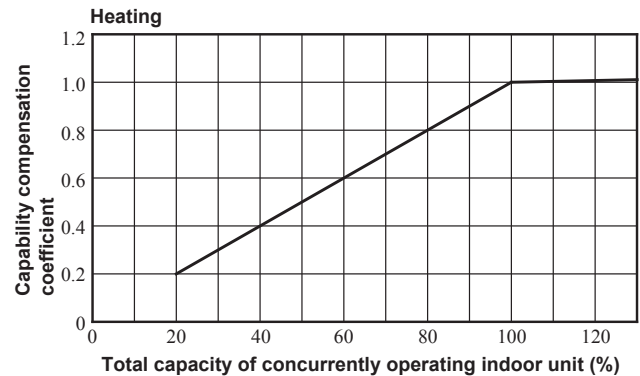
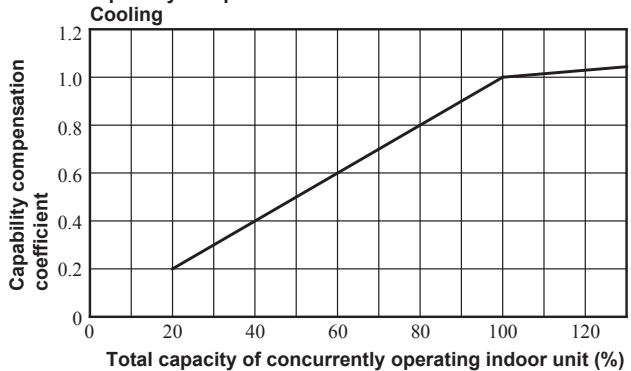

◆ Power consumption compensation coefficient

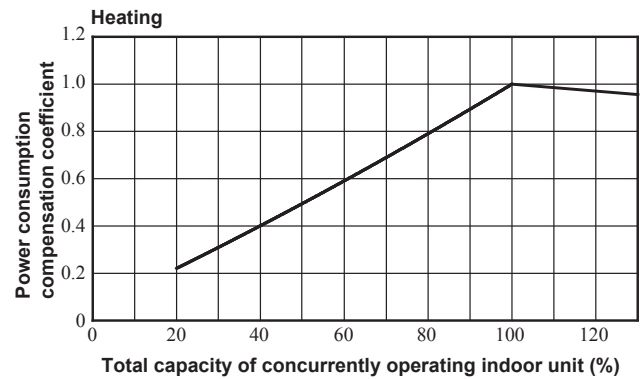
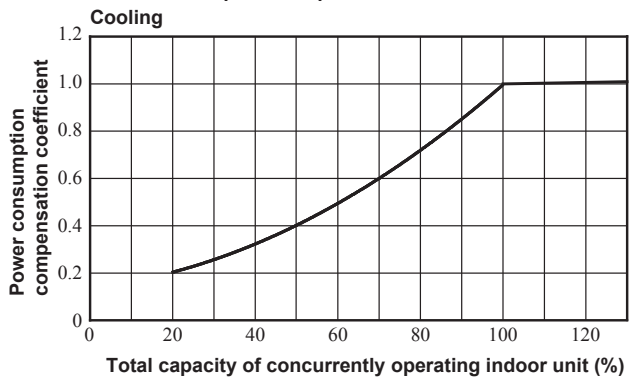

Model FDC950KXZXE1

◆ **Capability compensation coefficient**
Cooling

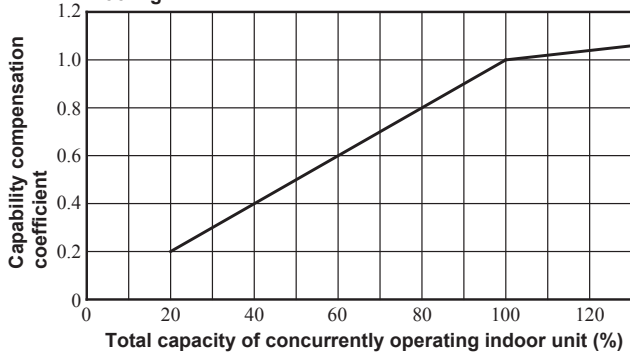

Heating

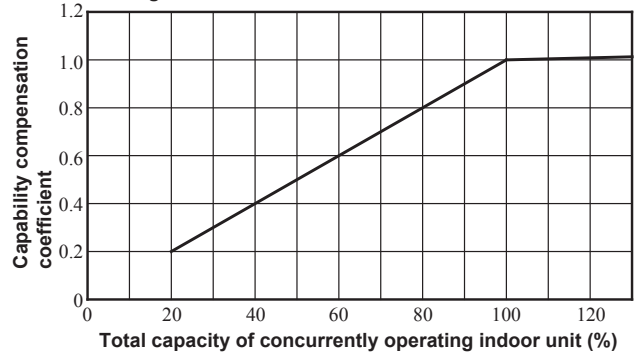

◆ **Power consumption compensation coefficient**
Cooling

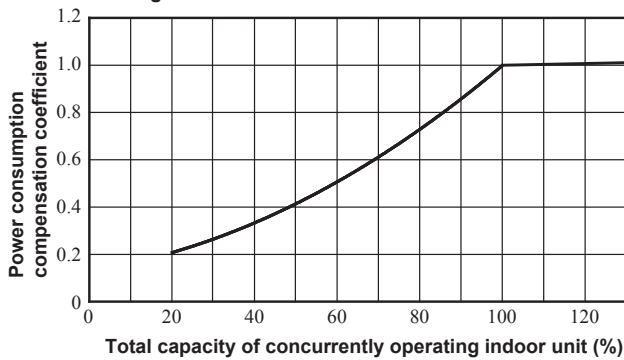

Heating

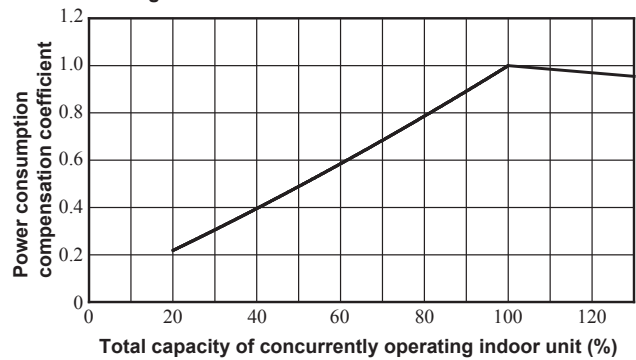

Model FDC1000KXZXE1

◆ **Capability compensation coefficient**
Cooling

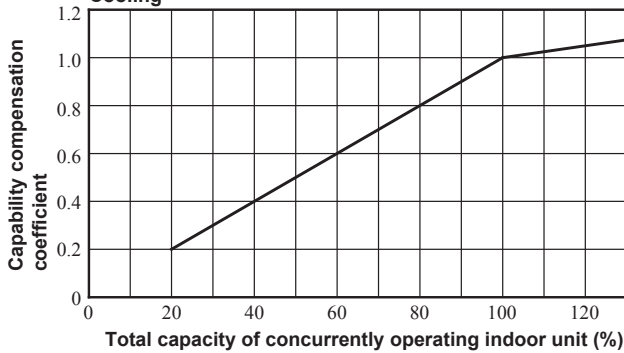

Heating

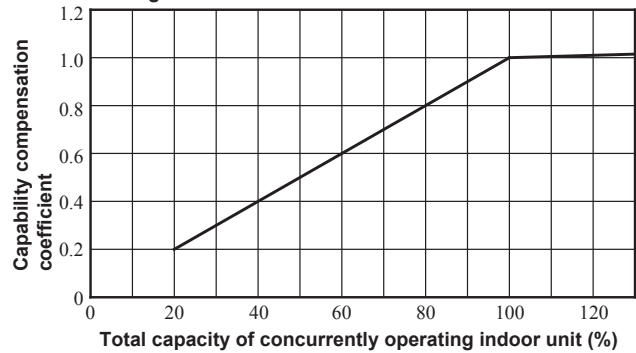

◆ **Power consumption compensation coefficient**
Cooling

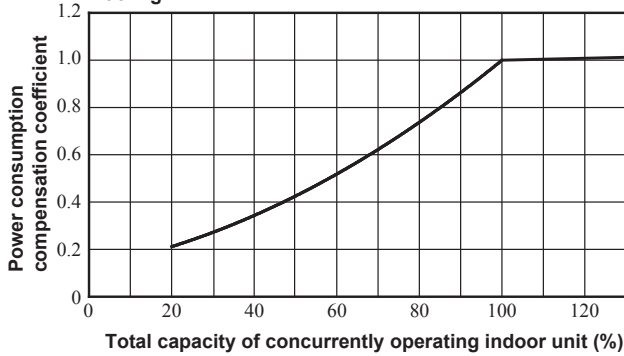

Heating

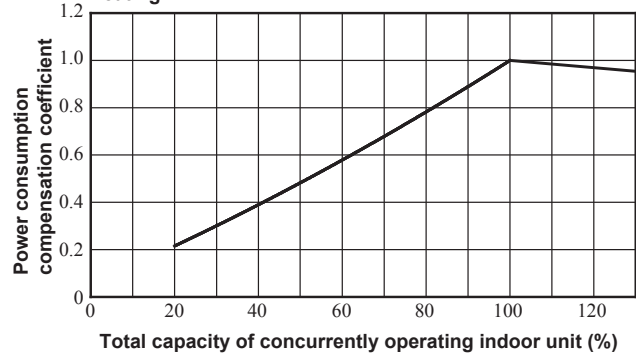

6. WARNINGS ON REFRIGERANT LEAKAGE

Check of concentration limit

The room in which the air conditioner is to be installed requires a design that in the event of refrigerant gas leaking out, its concentration will not exceed a set limit.

The refrigerant R410A which is used in the air conditioner is safe, without the toxicity or combustibility of ammonia, and is not restricted by laws to be imposed which protect the ozone layer. However, since it contains more than air, it poses the risk of suffocation if its concentration should rise excessively.

Suffocation from leakage of R410A is almost nonexistent. With the recent increase in the number of high concentration buildings, however, the installation of multi air conditioner systems is on the increase because of the need for effective use of floor space, individual control, energy conservation by curtailing heat and carrying power etc.

Most importantly, the multi air conditioner system is able to replenish a large amount of refrigerant compared with conventional individual air conditioners. If a single unit of the multi conditioner system is to be installed in a small room, select a suitable model and installation procedure so that if the refrigerant accidentally leaks out, its concentration does not reach the limit (and in the event of an emergency, measures can be made before injury can occur).

In a room where the concentration may exceed the limit, create an opening with adjacent rooms, or install mechanical ventilation combined with a gas leak detection device.

The concentration is as given below.

$$\frac{\text{Total amount of refrigerant (kg)}}{\text{Min. volume of the indoor unit installed room (m}^3\text{)}} \leq \text{Concentration limit (kg/m}^3\text{)}$$

The concentration limit of R410A which is used in multi air conditioners is 0.42kg/m³. (ISO5149)

Note(1) If there are 2 or more refrigerating systems in a single refrigerating device, the amounts of refrigerant should be as charged in each independent device.

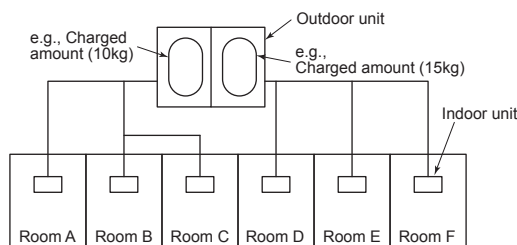

For the amount of charge in this example:
 The possible amount of leaked refrigerant gas in rooms A, B and C is 10kg.
 The possible amount of leaked refrigerant gas in rooms D, E and F is 15kg.

Important

Note(2) The standards for minimum room volume are as follows.

① No partition (shaded portion)

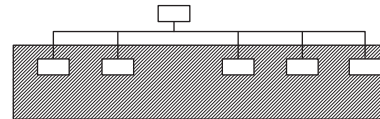

② When there is an effective opening with the adjacent room for ventilation of leaking refrigerant gas (opening without a door, or an opening 0.15% or larger than the respective floor spaces at the top or bottom of the door).

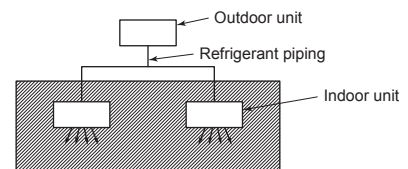

③ If an indoor unit is installed in each partitioned room and the refrigerant tubing is interconnected, the smallest of course becomes the object.

But when a mechanical ventilation is installed interlocked with a gas leakage detector in the smallest room where the density limit is exceeded, the volume of the next smallest room becomes the object.

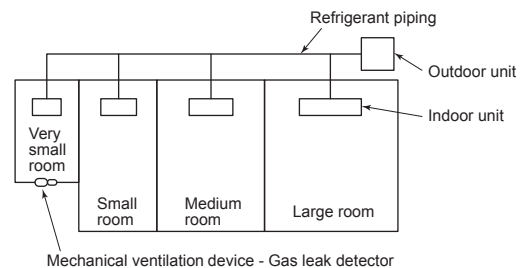

Note(3) The minimum indoor floor area compared with the amount of refrigerant is roughly as follows: (When the ceiling is 2.7m high)

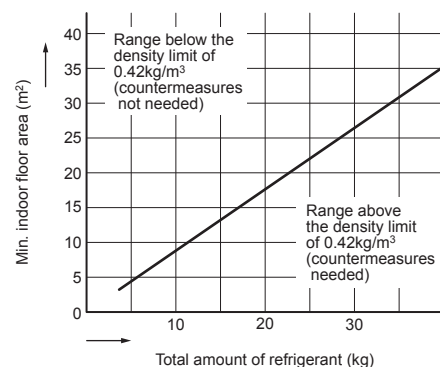

VRF INVERTER MULTI-SYSTEM AIR-CONDITIONERS



Air-Conditioning & Refrigeration Division
16-5, Konan 2-chome, Minato-ku, Tokyo, 108-8215 Japan
<http://www.mhi.co.jp>

Because of our policy of continuous improvement, we reserve the right to make changes in all specifications without notice.

©Copyright MITSUBISHI HEAVY INDUSTRIES, LTD.