

Water cooled screw chillers

ECOPLUS 050.1÷ 165.2

Cooling capacity from 166 kW to 604 kW

50Hz – Refrigerant: HFC 134a



McQuay is participating in the Eurovent Certification Programme. Product are as listed in the Eurovent Directory of Certified Products and on the web site www.eurovent-certification.com



Water cooled screw chillers McQuay ECOPLUS

McQuay water cooled ECOPLUS is a range of chillers using McQuay StarGate™ Frame 3200 single screw compressors. They are manufactured by McQuay to satisfy the requirements of the consultants and the end user. McQuay ECOPLUS units are designed to minimise energy costs while maximising the refrigeration capacities. Once again McQuay has developed a line of chillers unsurpassed in performance and quality that will meet the most stringent requirements of comfort cooling, ice storage and process applications.

McQuay's chiller design experience, combined with outstanding features makes the ECOPLUS chiller unmatched in the industry.

Lower noise – higher flexibility

The primary reason for quiet operation is the compressor design itself. McQuay continues the philosophy of a single main rotor with two adjacent twin rotating gaterotors. This allows the possibility to have two compression cycles per main rotor round and so a constant gas flow. This compression process completely eliminates gas pulsations, one of the most important noise source. The oil injection also results in a significant mechanical noise reduction.

The twin gas compressor discharge chambers are designed to act as attenuators, based on the harmonic wave principle with destructive interference, thus always resulting almost equal to zero. The extremely low noise compressor performance allows the use of ECOPLUS chiller for all applications.

Lower Vibration Levels – higher reliability

Because the moving components in the McQuay Single Screw Compressor are purely rotational and the loads are basically balanced, the dynamic forces and vibrations created by the system are very low. This reduced vibration results in less movement to refrigerant lines and other parts of the system.

The extremely low vibration levels, inherent with the single-screw design, will not pass through system piping and allow objectionable resonated sound to be carried into the building.

Code requirements

All water cooled units are designed and manufactured in accordance with applicable selections of the following which are equivalent to American Air-conditioning industry applicable codes:

Rating of chillers: EN 12055.

Construction of pressure vessel: TUV Standards (on request).

Electrical codes: IEC 204-1 CEI 44-5 Elect. & Safety Codes

Safety Codes: CEI-EN 60204–1 Codes.

Manufacturing Quality Stds: ISO 9001:2000.

Infinitely variable capacity control

Cooling capacity control is infinitely variable by means of a capacity slide controlled by microprocessor system. Each unit has infinitely variable capacity control from 100% down to 25% (one compressor unit), down to 12,5% (two compressors units). This modulation allows the compressor capacity to exactly match the building cooling load without any leaving evaporator water temperature fluctuation. This chilled water temperature fluctuation is avoided only with a stepless control, such as

McQuay International has. With a compressor load step control in fact, the compressor capacity, at partial loads, will be or too high or too low compared to the building cooling load. The result is a decrease in chiller energy costs, particularly at the part-load conditions at which the chiller operates most of the time.

Additionally, in some case there should be the possibility to avoid inertial tank in the water circuit.

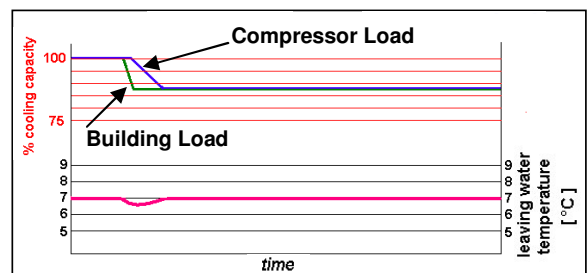
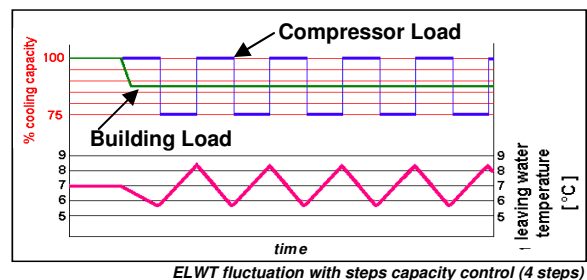

Unmatched serviceability

Field serviceability has not been sacrificed. Inspection covers allows visual inspection of the main screw and gaterotors.

Outstanding reliability features

Unsurpassed Efficiency

- Zero clearance fit between the two gaterotors and main screw rotor virtually eliminates leakage between the high and low-pressure sides during compression. Special gaterotor material made from an advanced composite, temperature stable material makes a zero clearance design possible.
- The McPower air-cooled chiller is equipped with the most advanced means of refrigerant flow control available. An electronic expansion valve coupled with the MicroTech II C Plus controller's control logic provides excellent operating efficiencies both at full and part load operation.
- Infinite unloading matches compressor capacity to load.
- Full factory testing of the unit with water hookups helps provides a trouble-free start-up. Extensive quality control checks during testing means that each equipment protection and operating control is properly adjusted and operates correctly before it leaves the factory. Factory-installed options minimize field expenses and startup labor.
- The rugged design of the single-screw compressor allows it to be tolerant of liquid slugging. McPower screw chiller will start and operate under conditions that would often destroy other compressors.
- Very low loading enhances the bearing and compressor reliability. Due to symmetrical compression taking place on both sides of the main screw rotor, balanced forces result in the elimination of the large radial force loads inherent in twin-screw compressors.
- Integral to the basic design of the single-screw compressor, the main screw rotor shaft and the gaterotor shafts cross at right angles in the compressor. The result is ample space to locate heavy duty bearings and increase compressor reliability since no limitations are placed on bearing design as found in twin-screw compressors.

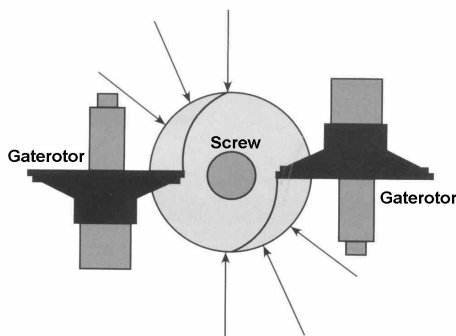

Single Screw Compressor

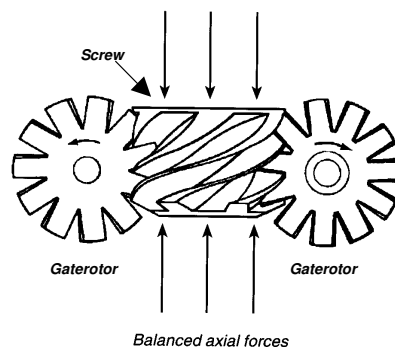

Single Screw Compressor

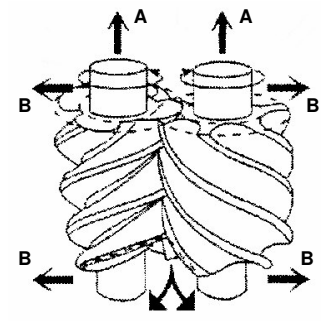

High Axial and Radial thrusts in TwinScrew Compressor

Twin Screw Compressor

General characteristics

Structure

The chiller is equipped with brackets directly installed on heat exchangers. The evaporator and the suction piping are appropriately insulated to prevent condensation. Unit is provided with lifting holes.

Screw compressors

The Stargate™ single-screw compressor has a well balanced compression mechanism which cancels the screw rotor load in both the radial and axial directions. Inherent to the basic single-screw compressor design is the virtually load-free operation, that gives main bearing design life of 3-4 times greater than twin-screws, and eliminates expensive and complicated thrust balancing schemes. The two exactly opposed gaterotors create two exactly opposed compression cycles. Compression is made at the lower and upper parts of the screw rotor at the same time, thus cancelling the radial loads. Also, both ends of the screw rotor are subjected to suction pressure only, which cancels the axial loads and eliminates the huge thrust loads inherent in twin-screw compressors (see images and drawings in this page).

Oil injection is used for these compressors in order to get high COP at high condensing pressure. The oil supplied to the compressor performs three basic functions: oil for capacity control actuation, oil for bearing lubrication, oil for sealing. The oil is injected via fixed ports in the casing around the rotor.

Compressors have an infinitely variable capacity control down to 25% of its total capacity. This control is made by means of capacity slides controlled by microprocessors.

The compressor is furnished with an integrated high efficiency oil separator to maximise oil extraction.

The compressor is provided with a liquid injection circuit to reach high sealing and oil cooling.

Standard start is star-delta type; Soft start type is available (as option) in order to have lower inrush current in almost all work conditions and to provide smooth, slow stepless acceleration and controlled slow deceleration reducing mechanical and electrical stress for even greater compressor/motor life.

Ecological HFC 134a refrigerant

McQuay has designed and optimized Stargate™ compressors to operate with HFC 134a, ecological refrigerant with zero ODP (Ozone Depletion Potential) and very low GWP (Global Warming Potential) that means low value of the “direct effect” in the formula of TEWI (Total Equivalent Warming Impact).

The HFC 134a refrigerant cycle has very good thermodynamic efficiency and pressure values for the condensing section are very low. This means less stress for the mechanical moving parts of the compressor and therefore a higher reliability for it. Also the discharge gas temperature is low thanks to using of this refrigerant; this means better performance for shell and tube condenser and always very good working condition for the oil.

This refrigerant is safe and chemically stable and is listed in ASHRAE Standard-34 (*Number Designation and Safety Classification For Refrigerants*) as “A-1” refrigerant: lowest toxicity, non-flammable.

HFC 134a doesn't have “Glide” therefore it's an AZEOTROPIC refrigerant. This helps to reach a perfect evaporator leaving water temperature control and doesn't give maintenance problem.

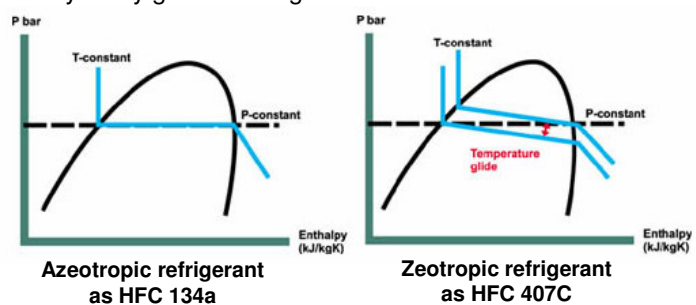

Evaporator

The units is supplied with optimised counter-flow evaporator single refrigerant pass that allows a perfect oil circulation and so a perfect oil return to the compressor. It is direct expansion with refrigerant inside the tubes and water outside (shell side) with carbon steel tube sheets, with straight copper tubes that are spirally wound internally for higher efficiencies, expanded on the tube plates. The external shell, is linked with an electrical heater to prevent freezing up to -28 C ambient temperature, commanded by a thermostat and is covered with a closed cell insulation material. Each evaporator has 1 or 2 circuits, one for each compressor and is manufactured in accordance to PED approval. The evaporator water outlet connections are provided with Victaulic Kit.

Condensers

Condensers are shell and cleanable, through-tube type. The unit has independent condensers, one per circuit. Each condenser has a carbon steel and seamless, integrally finned high efficiency copper tubes, roll expanded into heavy carbon steel tube sheets. Water heads are removable and include vent and drain plugs. Condensers come complete with liquid shut-off valve, spring loaded relief valve.

Electronic expansion valve (EEXV)

ECOPLUS water cooled chiller is equipped with the most advanced electronic expansion valve to achieve precise control of refrigerant mass flow. As today's system requires improved energy efficiency, tighter temperature control, wider range of operating conditions and incorporate features like remote monitoring and diagnostics, the application of electronic expansion valves becomes mandatory. ECOPLUS electronic expansion valve proposes features that makes it unique: short opening and closing time, high resolution, positive shut-off function to eliminate use of additional solenoid valve, highly linear flow capacity, continuous modulation of mass flow without stress in the refrigerant circuit and corrosion resistance stainless steel body.

EEXV strength point is the capacity to work with lower ΔP between high and low pressure side, than a thermostatic expansion valve. The electronic expansion valve allows the system to work with low condenser pressure (winter time) without any refrigerant flow problems and with a perfect chilled water leaving temperature control. Working with lower condensing pressure give you the possibility to reach a big energy saving.

Electrical control panel

Power and control are located into two sections of the main panel that is manufactured to insure protection for all weather conditions.

The power panel is fitted with an interlocked door main isolator to prevent access while power supply is on. Electrical panel is IP43.

Power section includes - The power section includes contactors, all compressors fuses and control circuit transformer. Additional space is provided for an easy installation of the various optional accessories provided to enhance the ECOPLUS units capabilities.

Certifications

All the ECOPLUS units are CE marked (89/392). McQuay Italia obtained ISO 9001:2000.

Water content in cooling circuits

The cooled water distribution circuits should have minimum water content to avoid excessive compressors start and stop.

In fact, each time the compressor starts up, an excessive quantity of oil goes from the compressor sump and simultaneously there is a rise in the temperature of the compressor motor's stator due to the inrush current during the start-up. To prevent damage to the compressors, McQuay has envisaged the application of a device to limit frequent stops and restarts.

During the span of one hour there will be no more than 6 starts of the compressor. The plant side should therefore ensure that the overall water content allows a more constant functioning of the unit and consequently greater environmental comfort. The minimum water content per unit should be calculated with a certain approximation using this simplified formula:

$$(1) \quad Q = 35,83 \times \frac{P \text{ (kW)}}{\Delta T \text{ (°C)}}$$

where:

Q = minimum water content per unit expressed in litres

P = minimum cooling capacity of the unit expressed in kW

ΔT = evaporator entering / leaving water temperature difference expressed in °C

For more accurate determination of quantity of water, it is advisable to contact the designer of the plant.

MicroTech II C Plus controller

MicroTech II C Plus controller is installed as standard on all the units; it can be used to modify unit set points and check control parameters. A display illustrates the machine's operating status, programable values and setpoints e.g. temperatures, and pressures of fluids (water, refrigerant). Device controls maximise the McQuay chillers energy efficiency and reliability characteristics. It uses sophisticated software with predictive logic to select the most energy efficient combination of compressor, expansion device and condenser fan to keep stable operating conditions and maximise energy efficiency. The compressors are automatically rotated to ensure equal operating hours. MicroTech II C Plus protects critical components in response to external signals from its system sensors measuring: motor temperatures, refrigerant gas and oil pressures, correct phases sequence and phase loss.

Control section - main features:

- Chillers enabled to work in partial failure condition thanks to the distributed multiprocessor logic system
- Full routine operation at condition of:
 - High ambient temperature value
 - High thermal load
 - High evaporator entering water temperature (start-up)
- Display of evaporator entering/leaving water temperature
- Display of condensing-evaporating temperature and pressure, suction and discharge superheat temperature for each circuit
- Leaving water cooled temperature regulation. Temperature tolerance $\pm 0,1$ °C
- Compressors and evaporator/condenser pumps hours counter
- Display of Status Safety Devices

- Start up numbers and compressors working hours equalization
- Excellent management of compressors load
- Cooling tower's fans management according to condensing pressure
- Automatic re-start in case of power supply interruption (adjustable)
- Soft Load
- Return Reset
- AOT Reset (optional)
- Setpoint Reset (optional)
- Demand limit or Current limit (optional)

Safety for each refrigerant circuit

High pressure (pressure switch)

Compressor overload (optional)

High Discharge Temperature on the compressor

Phase Monitor

Star / Delta Transition Failed

Low Delta Pressure between Suction and Discharge

Low pressure ratio

High oil pressure drop

Low oil pressure

System security

Phase monitor

Freeze protection

An evaporator's flow controller input (stops the unit)

Remote on/off input.

Regulation type

Proportional + integral + derivative regulation on the input probe of the evaporator water leaving temperature.

MicroTech II C Plus terminal

The MicroTech II C Plus terminal has following features:

- 4-lines by 20-character liquid crystal display back lighted
- Key-pad consisting of 15 keys " clear language display "
- Memory to protect the data
- General faults alarm led
- 4-level password access to modify the setting
- Service report displaying all running hours and general conditions
- Memorized alarm history to facilitate the fault's analysis.

PlantVisor™:

Solution for tele-maintenance and supervisory

MicroTech II C Plus can be monitored locally or via modem or GSM by PlantVisor™ supervision program.

PlantVisor™ is compatible with Windows NT, 2000, XP. It is based on 16 bit WEB technology.

It allows the followings functions.

- Unit status monitoring.
- Circuits status monitoring.
- Set-points modification.
- Alarms display.

MicroTech II C Plus remote control

MicroTech II C Plus is able to communicate to BMS (Building Management System) if the protocol is one of the following.

- CAREL.
- Modbus.
- LonWorks.
- BacNet point to point.

Standard Accessories (furnished on basic unit)

Star Delta Compressors starter – For low inrush current and reduced starting torque.

Phase monitor – The phase monitor controls that phases sequence is correct and controls the phase loss.

Evaporator connection water side Victaulic – Hydraulic joint with gasket for an easy and quick water connection.

Hour run meter – Digital compressors hour run meter.

General fault relay – Contactor for the alarm warning.

Alarm from external device – Microprocessor is able to receive an alarm signal from an external device (pump, etc.). User can decide if this alarm signal will stop or not the unit.

Discharge line shut off valves.

Options (on request)

100% total heat recovery – Produced with tube bundle placed in a single shell with the water condensers. Heat exchangers heads are provided with 2 connections for entering/leaving heat recovery water and 2 separate connections for condensing water.

Partial heat recovery – Produced with plate to plate heat exchangers installed on discharge side of compressor hot gas. These allow hot water to be produced up to a maximum temperature of + 50°C.

Compressor thermal overload relays - Safety devices against compressor motor overloading in addition to the normal protection envisaged by the electrical windings.

Ammeter and voltmeter - Digital meters of unit drawn amperes and voltage values, installed on the electrical control panel.

Condenser power factor correction - Installed on the electrical control panel to ensure it conforms to the plant rules. (McQuay advises maximum 0,9).

Flow switch - Supplied separately to be wired and installed on the evaporator water piping (by the customer).

20mm thicked evaporator insulation – Useful in really heavy operating conditions.

Suction line shut off valve – Suction shut-off valve installed on the suction port of the compressor to facilitate maintenance operation.

Cu-Ni 90-10 condenser – To work with sea water the heat exchangers are fitted with Cu-Ni tubes and special protection inside the end covers.

Rubber type antivibration mounts - Supplied separately, these are positioned under the base of the unit for “floor” installation.

Sound proof cabinet - Made of sheet metal and internally insulated, the sound proof cabinet is around the compressor/s to reach the best performance in noise reduction.

Witness tests - The units are normally tested at the test bench prior to the shipment. On request, a second test can be carried out, at customer’s presence, in accordance with the procedures indicated on the test form. (Not available for units with Glycol mixtures).

Soft start – Electronic starting device to reduce inrush current. An overload protection is included (no need of compressors thermal relays).

Over / Under Voltage – Phase monitor to control the minimum and maximum voltage value that the user can set.

Installation notes

Warning

Installation and maintenance are to be performed only by qualified personnel who are familiar with local codes and regulations, and who are experienced with this type of equipment. Must be avoided the unit installation in places that could be considered dangerous for all the maintenance operations.

Handling

The chiller is mounted on heavy wooden skids to protect the unit from accidental damage and to permit easy handling and moving. It is recommended that all moving and handling be performed with the skids under the unit when possible and that the skids not be removed until the unit is in the final location.

Spreader bars must be used to protect the control cabinet and the other areas of the chiller.

Location

A levelled and sufficiently strong floor is required. If necessary, additional structural members should be provided to transfer the weight of the unit to the nearest beams.

Rubber-in-shear isolators can be furnished and field placed under each corner of the package. A rubber anti-skid pad should be used under isolators if hold-down bolts are not used. Vibration isolator in all water piping connected to the chiller are recommended to avoid straining the piping and transmitting vibration and noise.

Operating limits

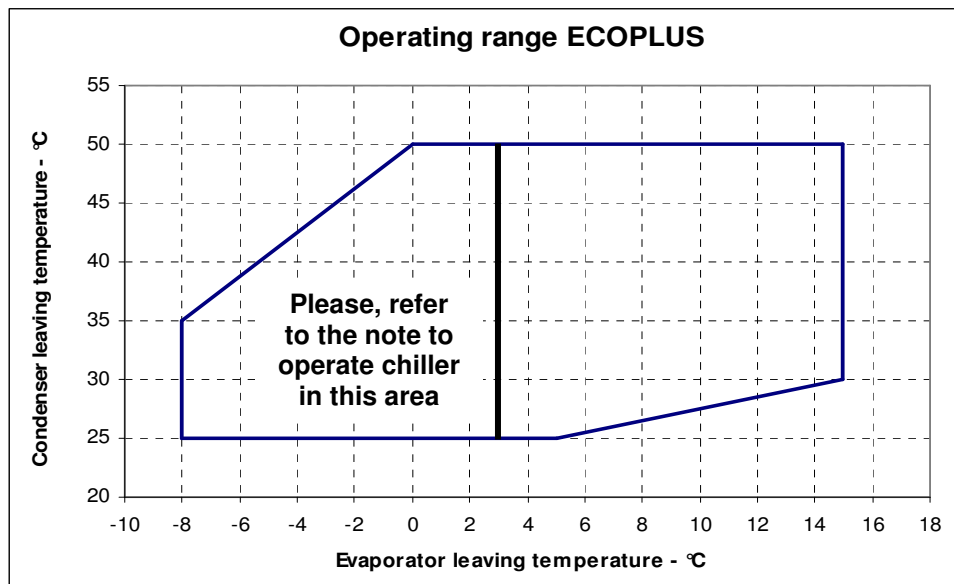

Note: the use of glycol is necessary for evaporator leaving water temperature below +3°C

Table 1 – Maximum and minimum evaporator and condenser water ΔT

Min ΔT evaporator/condenser water	°C	4
Max ΔT evaporator/condenser water	°C	8

Table 2 – Evaporator fouling factors

Fouling factors m ² °C / kW	Cooling capacity correction factor	Power input correction factor	COP correction factor
0,0176	1,000	1,000	1,000
0,0440	0,978	0,986	0,992
0,0880	0,957	0,974	0,983
0,1320	0,938	0,962	0,975

Table 3 – Condenser fouling factors

Fouling factors m ² °C / kW	Cooling capacity correction factor	Power input correction factor	COP correction factor
0,0440	1,000	1,000	1,000
0,0880	0,990	1,018	0,973
0,1320	0,981	1,036	0,945

Table 4 – Ethylene glycol and low ambient temperature correction factors

Air ambient temperature °C	-3	-8	-15	-23	-35
% of ethylene glycol by weight	10	20	30	40	50
Cooling capacity correction factor	0,991	0,982	0,972	0,961	0,946
Power input correction factor	0,996	0,992	0,986	0,976	0,966
Flow rate correction factor	1,013	1,040	1,074	1,121	1,178
Water pressure drops correction factor	1,070	1,129	1,181	1,263	1,308

Table 5 – Low temperature operation performance factors

Ethylene glycol/water leaving temperature °C	2	0	-2	-4	-6	-8
Min. % of ethylene glycol	10	20	20	30	30	30
Cooling capacity correction factor	0,842	0,785	0,725	0,670	0,613	0,562
Power input compressors correction factor	0,95	0,94	0,92	0,89	0,87	0,84

Nomenclature

ECOPLUS 120 . 2 SE ST 134

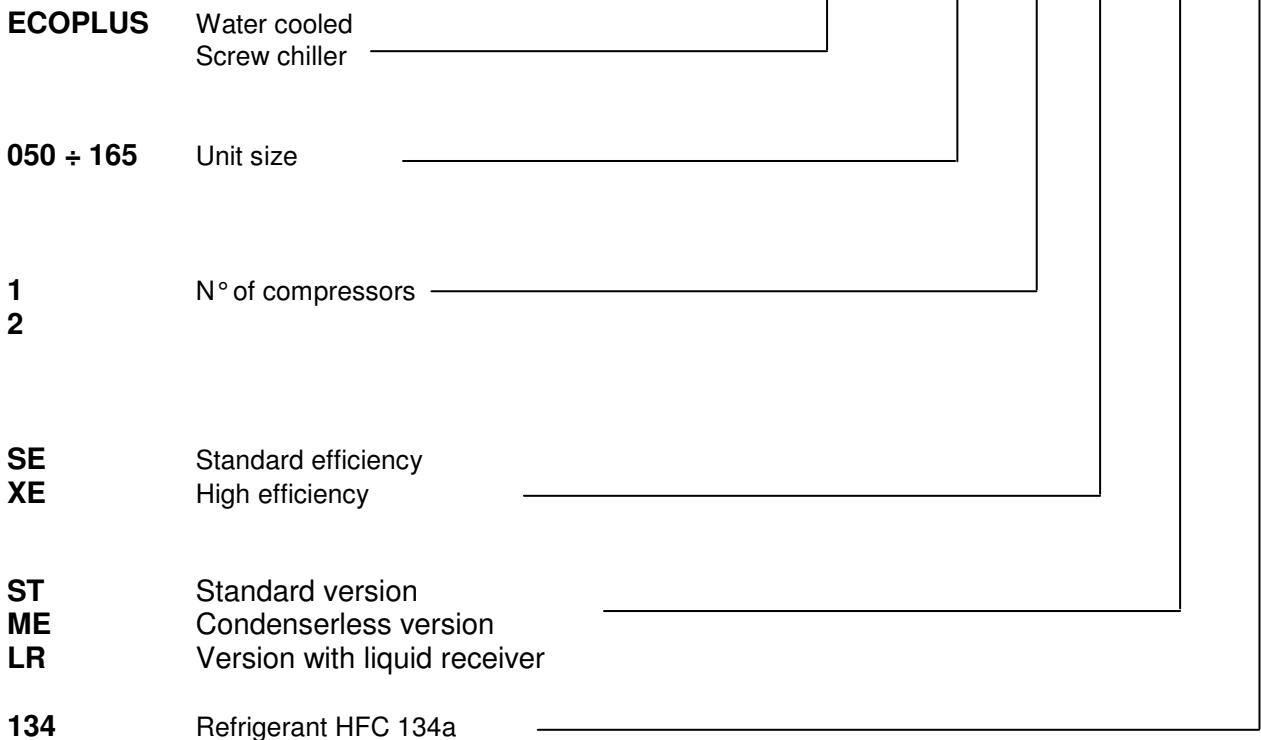

Physical data ECOPLUS SE with HFC 134a

ECOPLUS unit size		050.1	060.1	073.1	080.1	100.2
Cooling capacity (1)	kW	165,5	201,2	252,8	280,4	333,9
Power input (1)	kW	42,1	50,7	64,9	75,4	84,3
McQuay Stargate™ Screw compressor	N.	1	1	1	1	2
Refrigerant circuits	N.	1	1	1	1	2
Refrigerant charge HFC 134a	kg	50	50	50	50	100
Min % of capacity reduction	%	25	25	25	25	12,5

Evaporator

Evaporators / water volume	N./l	1 / 60	1 / 56	1 / 123	1 / 123	1 / 118
Max operating pressure	bar	10,5	10,5	10,5	10,5	10,5

Condenser

Condensers / water volume	N./l	1 / 13	1 / 15	1 / 15	1 / 15	2 / 26
Max operating pressure	bar	10,5	10,5	10,5	10,5	10,5

Weight and dimensions

Standard unit shipping weight	kg	1393	1410	1503	1503	2687
Standard unit operating weight	kg	1470	1480	1650	1650	2840
Unit length	mm	3435	3435	3435	3435	4305
Unit width	mm	920	920	920	920	860
Unit height	mm	1860	1860	1860	1860	1880

Note: (1) Nominal cooling capacity and power input are based on: 12/7 °C entering/leaving evaporator water temperature; 30/35 °C entering/leaving condenser water temperature.

Physical data ECOPLUS SE with HFC 134a

ECOPLUS unit size		110.2	120.2	133.2	146.2	165.2
Cooling capacity (1)	kW	372,2	402,5	448,3	493,7	555,7
Power input (1)	kW	93,1	101,4	115,1	129,0	150,2
McQuay Stargate™ Screw compressor	N.	2	2	2	2	2
Refrigerant circuits	N.	2	2	2	2	2
Refrigerant charge HFC 134a	kg	100	100	100	100	100
Min % of capacity reduction	%	12,5	12,5	12,5	12,5	12,5

Evaporator

Evaporators / water volume	N./l	1 / 113	1 / 113	1 / 173	1 / 168	1 / 168
Max operating pressure	bar	10,5	10,5	10,5	10,5	10,5

Condenser

Condensers / water volume	N./l	2 / 28	2 / 30	2 / 30	2 / 30	2 / 30
Max operating pressure	bar	10,5	10,5	10,5	10,5	10,5

Weight and dimensions

Standard unit shipping weight	kg	2697	2702	2757	2762	2762
Standard unit operating weight	kg	2850	2860	2970	2970	2970
Unit length	mm	4305	4305	4305	4305	4305
Unit width	mm	860	860	860	860	860
Unit height	mm	1880	1880	1880	1880	1880

Note: (1) Nominal cooling capacity and power input are based on: 12/7 °C entering/leaving evaporator water temperature; 30/35 °C entering/leaving condenser water temperature.

Physical data ECOPLUS XE with HFC 134a

ECOPLUS unit size		050.1	060.1	073.1	080.1	100.2
Cooling capacity (1)	kW	186,4	223,3	276,5	306,7	366,3
Power input (1)	kW	39,7	48,1	59,3	71,4	79,3
McQuay Stargate™ Screw compressor	N.	1	1	1	1	2
Refrigerant circuits	N.	1	1	1	1	2
Refrigerant charge HFC 134a	kg	50	50	50	50	100
Min % of capacity reduction	%	25	25	25	25	12,5
Evaporator						
Evaporators / water volume	N./l	1 / 125	1 / 120	1 / 110	1 / 110	1 / 170
Max operating pressure	bar	10,5	10,5	10,5	10,5	10,5
Condenser						
Condensers / water volume	N./l	1 / 22	1 / 25	1 / 25	1 / 25	2 / 44
Max operating pressure	bar	10,5	10,5	10,5	10,5	10,5
Weight and dimensions						
Standard unit shipping weight	kg	1650	1665	1680	1680	2800
Standard unit operating weight	kg	1800	1810	1820	1820	3020
Unit length	mm	3435	3435	3435	3435	4305
Unit width	mm	920	920	920	920	860
Unit height	mm	1860	1860	1860	1860	1880

Note: (1) Nominal cooling capacity and power input are based on: 12/7 °C entering/leaving evaporator water temperature; 30/35 °C entering/leaving condenser water temperature.

Physical data ECOPLUS XE with HFC 134a

ECOPLUS unit size		110.2	120.2	133.2	146.2	165.2
Cooling capacity (1)	kW	408,2	443,6	496,0	540,5	603,9
Power input (1)	kW	87,2	95,0	104,8	114,4	137,7
McQuay Stargate™ Screw compressor	N.	2	2	2	2	2
Refrigerant circuits	N.	2	2	2	2	2
Refrigerant charge HFC 134a	kg	100	100	100	100	100
Min % of capacity reduction	%	12,5	12,5	12,5	12,5	12,5
Evaporator						
Evaporators / water volume	N./l	1 / 285	1 / 285	1 / 280	1 / 280	1 / 280
Max operating pressure	bar	10,5	10,5	10,5	10,5	10,5
Condenser						
Condensers / water volume	N./l	2 / 47	2 / 50	2 / 59	2 / 68	2 / 68
Max operating pressure	bar	10,5	10,5	10,5	10,5	10,5
Weight and dimensions						
Standard unit shipping weight	kg	2945	2955	2975	2990	2990
Standard unit operating weight	kg	3280	3290	3315	3340	3340
Unit length	mm	4305	4305	4305	4305	4305
Unit width	mm	860	860	860	860	860
Unit height	mm	1880	1880	1880	1880	1880

Note: (1) Nominal cooling capacity and power input are based on: 12/7 °C entering/leaving evaporator water temperature; 30/35 °C entering/leaving condenser water temperature.

Electrical data ECOPLUS SE with HFC 134a

ECOPLUS unit size		050.1	060.1	073.1	080.1	100.2
Standard voltage (1)		400 V - 3f - 50 Hz				
Nominal unit current (2)	A	81	92	111	131	163
Max unit current (3)	A	112	133	164	174	225
Max unit inrush current (4)	A	288	288	288	288	349
Max unit current for wires sizing (5)	A	124	147	165	190	248

ECOPLUS unit size		110.2	120.2	133.2	146.2	165.2
Standard voltage (1)		400 V - 3f - 50 Hz				
Nominal unit current (2)	A	174	184	202	221	260
Max unit current (3)	A	246	266	299	329	345
Max unit inrush current (4)	A	353	357	366	371	439
Max unit current for wires sizing (5)	A	271	294	312	330	380

- Note:** (1) Allowed voltage tolerance $\pm 10\%$. Voltage unbalance between phases must be within $\pm 3\%$.
(2) Absorbed current referred to nominal condition: 12/7 °C entering/leaving evaporator water temperature; 30/35 °C entering/leaving condenser water temperature.
(3) Absorbed current referred to the following conditions: 14/9 °C entering/leaving evaporator water temperature; 45/50°C entering/leaving condenser water temperature.
(4) Inrush compressor's current for unit with one compressor OR 75% of nominal absorbed current of compressor n°1 + inrush current of last compressor (n°2).
(5) Compressor FLA (Full Load Ampere).

Electrical data ECOPLUS XE with HFC 134a

ECOPLUS unit size		050.1	060.1	073.1	080.1	100.2
Standard voltage (1)		400 V - 3f - 50 Hz				
Nominal unit current (2)	A	79	89	103	124	157
Max unit current (3)	A	108	128	154	162	215
Max unit inrush current (4)	A	288	288	288	288	347
Max unit current for wires sizing (5)	A	124	147	165	190	248

ECOPLUS unit size		110.2	120.2	133.2	146.2	165.2
Standard voltage (1)		400 V - 3f - 50 Hz				
Nominal unit current (2)	A	167	175	188	201	238
Max unit current (3)	A	234	253	276	299	313
Max unit inrush current (4)	A	351	354	359	363	430
Max unit current for wires sizing (5)	A	271	294	312	330	380

- Note:** (1) Allowed voltage tolerance $\pm 10\%$. Voltage unbalance between phases must be within $\pm 3\%$.
(2) Absorbed current referred to nominal condition: 12/7 °C entering/leaving evaporator water temperature; 30/35 °C entering/leaving condenser water temperature.
(3) Absorbed current referred to the following conditions: 14/9 °C entering/leaving evaporator water temperature; 45/50°C entering/leaving condenser water temperature.
(4) Inrush compressor's current for unit with one compressor OR 75% of nominal absorbed current of compressor n°1 + inrush current of last compressor (n°2).
(5) Compressor FLA (Full Load Ampere).

Sound pressure level ECOPLUS

ECOPLUS unit size	Sound pressure level at 1 m from the in free field (rif. 2×10^{-5})								
	63 Hz	125 Hz	250 Hz	500 Hz	1000 Hz	2000 Hz	4000 Hz	8000 Hz	dBA
050.1	58	58	63,5	68,5	63	64	53	49,5	69,7
060.1	58	58	63,5	68,5	63	64	53	49,5	69,7
073.1	58	58	63,5	68,5	63	64	53	49,5	69,7
080.1	58	58	63,5	68,5	63	64	53	49,5	69,7
100.2	60	60	65,5	70,5	65	66	55	51,5	71,7
110.2	60	60	65,5	70,5	65	66	55	51,5	71,7
120.2	60	60	65,5	70,5	65	66	55	51,5	71,7
133.2	60	60	65,5	70,5	65	66	55	51,5	71,7
146.2	60	60	65,5	70,5	65	66	55	51,5	71,7
165.2	60	60	65,5	70,5	65	66	55	51,5	71,7

Note: Average sound pressure level rated in accordance to ISO 3744, free field semispheric conditions.

Sound pressure level ECOPLUS with Sound Proof Cabinet

ECOPLUS unit size	Sound pressure level at 1 m from the in free field (rif. 2×10^{-5})								
	63 Hz	125 Hz	250 Hz	500 Hz	1000 Hz	2000 Hz	4000 Hz	8000 Hz	dBA
050.1	55,9	55,2	59,6	63,9	57,7	58,5	47,7	44,2	64,7
060.1	55,9	55,2	59,6	63,9	57,7	58,5	47,7	44,2	64,7
073.1	55,9	55,2	59,6	63,9	57,7	58,5	47,7	44,2	64,7
080.1	55,9	55,2	59,6	63,9	57,7	58,5	47,7	44,2	64,7
100.2	57,9	57,2	61,6	65,9	59,7	60,5	49,7	46,2	66,7
110.2	57,9	57,2	61,6	65,9	59,7	60,5	49,7	46,2	66,7
120.2	57,9	57,2	61,6	65,9	59,7	60,5	49,7	46,2	66,7
133.2	57,9	57,2	61,6	65,9	59,7	60,5	49,7	46,2	66,7
146.2	57,9	57,2	61,6	65,9	59,7	60,5	49,7	46,2	66,7
165.2	57,9	57,2	61,6	65,9	59,7	60,5	49,7	46,2	66,7

Note: Average sound pressure level rated in accordance to ISO 3744, free field semispheric conditions.

Sound pressure level correction factor for different distances

ECOPLUS unit size	Distance (m)					
	1	5	10	15	20	25
050.1	0	8,7	13,7	16,9	19,2	21,1
060.1	0	8,7	13,7	16,9	19,2	21,1
073.1	0	8,7	13,7	16,9	19,2	21,1
080.1	0	8,7	13,7	16,9	19,2	21,1
100.2	0	8,7	13,7	16,9	19,2	21,1
110.2	0	8,4	13,4	16,5	18,8	20,6
120.2	0	8,3	13,3	16,4	18,7	20,5
133.2	0	8,3	13,3	16,4	18,7	20,5
146.2	0	8,3	13,3	16,4	18,7	20,5
165.2	0	8,3	13,3	16,4	18,7	20,5

Standard ratings ECOPLUS SE 050.1 ÷ 100.2

ECOPLUS unit size	Evaporator leaving water temp. (°C)	ENTERING CONDENSER WATER TEMPERATURE °C									
		25		30		35		40		45	
		Cooling capacity (kW)	Power input (kW)	Cooling capacity (kW)	Power input (kW)	Cooling capacity (kW)	Power input (kW)	Cooling capacity (kW)	Power input (kW)	Cooling capacity (kW)	Power input (kW)
050.1	4	157,6	36,5	151,1	41,2	144,3	46,2	137,4	51,7	130,1	57,6
	5	162,4	36,8	155,8	41,5	148,9	46,5	141,8	52,0	134,4	58,0
	6	167,4	37,0	160,6	41,8	153,6	46,8	146,4	52,4	138,7	58,3
	7	172,3	37,3	165,5	42,1	158,4	47,2	151,0	52,7	143,3	58,7
	8	177,5	37,6	170,5	42,3	163,3	47,5	155,6	53,0	147,8	59,0
	9	182,6	37,8	175,5	42,6	168,1	47,8	160,5	53,4	152,4	59,4
060.1	4	191,5	44,0	183,6	49,6	175,5	55,7	166,9	62,3	157,7	69,4
	5	197,3	44,3	189,4	50,0	181,1	56,1	172,3	62,7	162,9	69,8
	6	203,4	44,7	195,3	50,4	186,7	56,5	177,8	63,1	168,3	70,2
	7	209,5	45,0	201,2	50,7	192,5	56,9	183,4	63,5	173,8	70,6
	8	215,7	45,3	207,2	51,1	198,4	57,3	189,1	63,9	179,2	71,1
	9	222,0	45,6	213,3	51,5	204,4	57,7	194,9	64,4	184,9	71,5
073.1	4	240,7	56,3	230,4	63,3	219,8	70,8	208,5	79,0	196,6	87,8
	5	248,2	56,8	237,7	63,8	226,8	71,4	215,4	79,6	203,1	88,4
	6	255,9	57,3	245,1	64,4	234,0	72,0	222,3	80,2	209,8	89,0
	7	263,6	57,8	252,8	64,9	241,3	72,6	229,4	80,8	216,6	89,6
	8	271,5	58,3	260,4	65,5	248,7	73,2	236,5	81,4	223,5	90,3
	9	279,5	58,8	268,2	66,1	256,3	73,8	243,8	82,1	230,5	91,0
080.1	4	267,2	66,3	255,5	72,1	243,5	78,7	230,9	86,1	217,7	94,4
	5	275,8	67,5	263,4	73,2	251,2	79,7	238,3	87,1	224,8	95,3
	6	284,5	68,6	271,8	74,3	259,0	80,8	245,9	88,1	232,1	96,3
	7	293,5	69,8	280,4	75,4	266,9	81,9	253,6	89,2	239,5	97,4
	8	304,8	71,3	289,2	76,6	275,3	83,0	261,4	90,3	247,1	98,5
	9	314,3	72,6	300,6	78,2	283,9	84,2	269,3	91,4	254,8	99,6
100.2	4	317,9	73,2	304,7	82,5	291,1	92,6	276,9	103,5	262,0	115,4
	5	327,6	73,7	314,3	83,1	300,3	93,2	285,8	104,2	270,8	116,1
	6	337,7	74,2	324,0	83,7	309,8	93,9	295,1	104,9	279,7	116,8
	7	347,8	74,7	333,9	84,3	319,5	94,5	304,5	105,6	288,8	117,5
	8	358,2	75,3	344,0	84,9	329,3	95,2	313,9	106,3	298,1	118,3
	9	368,8	75,8	354,3	85,5	339,3	95,9	323,6	107,0	307,5	119,0

Note: Nominal cooling capacity and power input are based on $\Delta T=5^{\circ}\text{C}$ entering/leaving condenser water temperature; evaporator fouling factor=0,0176 $\text{m}^2\text{ }^{\circ}\text{C}/\text{kW}$; condenser fouling factor=0,0440 $\text{m}^2\text{ }^{\circ}\text{C}/\text{kW}$.

Standard ratings ECOPLUS SE 110.2 ÷ 165.2

ECOPLUS unit size	Evaporator leaving water temp. (°C)	ENTERING CONDENSER WATER TEMPERATURE °C									
		25		30		35		40		45	
		Cooling capacity (kW)	Power input (kW)	Cooling capacity (kW)	Power input (kW)	Cooling capacity (kW)	Power input (kW)	Cooling capacity (kW)	Power input (kW)	Cooling capacity (kW)	Power input (kW)
110.2	4	354,2	80,8	339,5	91,1	324,2	102,2	308,3	114,3	291,5	127,3
	5	365,2	81,4	350,2	91,8	334,6	102,9	318,4	115,0	301,3	128,1
	6	376,5	82,0	361,1	92,4	345,3	103,7	328,7	115,8	311,2	128,9
	7	387,8	82,6	372,2	93,1	356,1	104,4	339,1	116,6	321,4	129,7
	8	399,4	83,2	383,6	93,8	367,0	105,1	349,8	117,4	331,7	130,5
	9	411,3	83,8	395,0	94,5	378,2	105,9	360,6	118,2	342,2	131,3
120.2	4	383,2	88,1	367,5	99,3	351,1	111,5	333,9	124,6	315,6	138,8
	5	394,9	88,7	378,9	100,0	362,3	112,2	344,7	125,4	326,1	139,6
	6	407,0	89,3	390,7	100,7	373,7	113,0	355,8	126,2	336,8	140,4
	7	419,1	90,0	402,5	101,4	385,2	113,8	367,0	127,0	347,6	141,3
	8	431,6	90,6	414,6	102,2	397,0	114,6	378,3	127,9	358,6	142,2
	9	444,1	91,3	426,8	102,9	408,9	115,4	390,0	128,8	369,9	143,1
133.2	4	426,9	99,9	409,2	112,5	390,8	126,1	371,3	140,8	350,7	156,8
	5	440,0	100,7	422,0	113,4	403,1	127,0	383,4	141,8	362,3	157,7
	6	453,4	101,5	435,0	114,2	415,8	128,0	395,6	142,8	374,1	158,8
	7	467,0	102,3	448,3	115,1	428,7	129,0	408,0	143,8	386,1	159,8
	8	480,8	103,1	461,6	116,1	441,7	129,9	420,7	144,9	398,3	160,9
	9	494,8	103,9	475,3	117,0	455,0	131,0	433,4	145,9	410,7	162,0
146.2	4	470,5	111,8	450,7	125,8	430,2	140,9	408,6	157,2	385,5	174,8
	5	484,9	112,8	464,8	126,8	443,8	142,0	421,8	158,3	398,3	176,0
	6	499,6	113,8	479,2	127,9	457,7	143,1	435,2	159,5	411,2	177,2
	7	514,5	114,7	493,7	129,0	471,8	144,3	448,8	160,7	424,3	178,4
	8	529,7	115,7	508,4	130,1	486,2	145,4	462,6	161,9	437,6	179,7
	9	545,1	116,7	523,3	131,2	500,7	146,6	476,7	163,2	451,1	181,0
165.2	4	524,8	131,5	501,1	143,0	476,3	156,1	451,6	170,9	426,2	187,5
	5	541,6	133,6	517,3	145,1	492,0	158,1	465,9	172,8	440,0	189,4
	6	563,7	136,5	533,9	147,3	508,0	160,3	481,1	174,8	454,2	191,3
	7	581,7	138,9	555,7	150,2	524,4	162,5	496,8	177,0	468,4	193,3
	8	600,0	141,3	573,4	152,6	541,0	164,7	512,8	179,2	483,4	195,4
	9	618,6	143,8	591,4	155,1	563,2	167,8	529,2	181,5	499,1	197,6

Note: Nominal cooling capacity and power input are based on $\Delta T=5^{\circ}\text{C}$ entering/leaving condenser water temperature; evaporator fouling factor=0,0176 $\text{m}^2\text{ }^{\circ}\text{C}/\text{kW}$; condenser fouling factor=0,0440 $\text{m}^2\text{ }^{\circ}\text{C}/\text{kW}$.

Standard ratings ECOPLUS XE 050.1 ÷ 100.2

ECOPLUS unit size	Evaporator leaving water temp. (°C)	ENTERING CONDENSER WATER TEMPERATURE °C									
		25		30		35		40		45	
		Cooling capacity (kW)	Power input (kW)	Cooling capacity (kW)	Power input (kW)	Cooling capacity (kW)	Power input (kW)	Cooling capacity (kW)	Power input (kW)	Cooling capacity (kW)	Power input (kW)
050.1	4	176,3	34,6	168,8	39,1	161,1	44,0	153,1	49,3	144,8	55,0
	5	182,2	34,7	174,6	39,3	166,7	44,3	158,4	49,6	150,0	55,3
	6	188,3	34,9	180,5	39,5	172,3	44,5	164,0	49,8	155,3	55,5
	7	194,5	35,0	186,4	39,7	178,2	44,7	169,6	50,1	160,8	55,8
	8	200,9	35,2	192,6	39,9	184,1	45,0	175,4	50,4	166,3	56,1
	9	207,2	35,3	198,9	40,1	190,1	45,2	181,3	50,6	172,0	56,4
060.1	4	211,4	41,9	202,5	47,3	193,3	53,2	183,8	59,6	173,7	66,5
	5	218,4	42,1	209,3	47,6	199,9	53,5	190,1	59,9	179,8	66,8
	6	225,6	42,3	216,3	47,9	206,7	53,8	196,6	60,3	186,2	67,1
	7	232,9	42,5	223,3	48,1	213,5	54,1	203,3	60,6	192,6	67,5
	8	240,3	42,7	230,6	48,4	220,5	54,5	210,1	60,9	199,2	67,8
	9	247,8	42,9	237,9	48,7	227,6	54,8	217,0	61,3	205,9	68,2
073.1	4	261,6	51,6	250,6	58,3	239,2	65,5	227,3	73,2	214,8	81,6
	5	270,4	51,9	259,0	58,6	247,4	65,9	235,3	73,7	222,5	82,0
	6	279,2	52,2	267,7	59,0	255,7	66,3	243,3	74,1	230,2	82,5
	7	288,3	52,5	276,5	59,3	264,3	66,7	251,5	74,5	238,1	82,9
	8	297,5	52,8	285,4	59,7	273,0	67,1	260,0	75,0	246,3	83,4
	9	306,9	53,0	294,6	60,1	281,8	67,5	268,5	75,4	254,5	83,9
080.1	4	291,0	63,1	278,8	68,3	266,0	74,2	252,8	80,9	239,0	88,4
	5	300,4	64,2	287,9	69,3	275,0	75,2	261,5	81,8	247,3	89,3
	6	309,9	65,2	297,2	70,3	283,9	76,1	270,2	82,7	255,7	90,2
	7	319,7	66,3	306,7	71,4	293,2	77,1	279,0	83,7	264,4	91,1
	8	329,6	67,4	316,4	72,4	302,5	78,2	288,2	84,7	273,2	92,1
	9	339,7	68,6	326,1	73,5	312,1	79,3	297,4	85,7	282,2	93,1
100.2	4	346,6	68,9	332,1	78,1	317,0	87,8	301,5	98,4	285,4	109,8
	5	358,0	69,3	343,2	78,5	327,8	88,3	312,0	98,9	295,6	110,3
	6	369,8	69,6	354,6	78,9	338,9	88,8	322,7	99,4	305,9	110,8
	7	381,7	69,9	366,3	79,3	350,2	89,2	333,6	99,9	316,5	111,4
	8	394,0	70,2	378,1	79,7	361,7	89,7	344,7	100,4	327,3	112,0
	9	406,4	70,5	390,2	80,0	373,5	90,2	356,2	101,0	338,4	112,5

Note: Nominal cooling capacity and power input are based on $\Delta T=5^{\circ}\text{C}$ entering/leaving condenser water temperature; evaporator fouling factor= $0,0176\text{ m}^2\text{ }^{\circ}\text{C}/\text{kW}$; condenser fouling factor= $0,0440\text{ m}^2\text{ }^{\circ}\text{C}/\text{kW}$.

Standard ratings ECOPLUS XE 110.2 ÷ 165.2

ECOPLUS unit size	Evaporator leaving water temp. (°C)	ENTERING CONDENSER WATER TEMPERATURE °C									
		25		30		35		40		45	
		Cooling capacity (kW)	Power input (kW)	Cooling capacity (kW)	Power input (kW)	Cooling capacity (kW)	Power input (kW)	Cooling capacity (kW)	Power input (kW)	Cooling capacity (kW)	Power input (kW)
110.2	4	386,1	75,9	370,0	85,9	353,3	96,7	335,9	108,3	317,8	120,8
	5	399,0	76,2	382,4	86,4	365,3	97,2	347,6	108,8	329,1	121,4
	6	412,2	76,6	395,2	86,8	377,7	97,7	359,6	109,4	340,6	122,0
	7	425,5	76,9	408,2	87,2	390,3	98,2	371,7	110,0	352,5	122,6
	8	439,2	77,3	421,5	87,7	403,1	98,7	384,3	110,6	364,5	123,2
120.2	4	419,9	82,7	402,5	93,6	384,5	105,3	365,8	118,0	346,0	131,6
	5	433,7	83,1	415,9	94,1	397,6	105,9	378,4	118,6	358,2	132,2
	6	447,8	83,4	429,6	94,5	410,9	106,4	391,3	119,2	370,7	132,9
	7	462,3	83,8	443,6	95,0	424,5	107,0	404,5	119,8	383,5	133,5
	8	476,9	84,2	457,9	95,5	438,3	107,5	417,9	120,4	396,4	134,2
133.2	4	469,4	91,2	450,0	103,3	430,0	116,2	409,2	130,2	387,3	145,2
	5	484,8	91,6	465,0	103,8	444,7	116,8	423,3	130,8	401,0	145,9
	6	500,7	92,1	480,4	104,3	459,5	117,4	437,8	131,5	415,0	146,6
	7	516,8	92,5	496,0	104,8	474,7	118,0	452,5	132,2	429,2	147,3
	8	533,1	92,9	512,0	105,3	490,2	118,6	467,5	132,8	443,7	148,0
146.2	4	511,7	99,6	490,9	112,7	469,5	126,9	447,1	142,1	423,6	158,6
	5	528,4	100,0	507,2	113,2	485,2	127,5	462,5	142,8	438,5	159,3
	6	545,4	100,4	523,8	113,8	501,4	128,1	478,0	143,5	453,5	160,1
	7	562,7	100,9	540,5	114,4	517,8	128,8	494,0	144,2	469,0	160,8
	8	580,3	101,3	557,7	114,9	534,5	129,4	510,2	144,9	484,6	161,6
165.2	4	571,0	121,8	547,8	132,0	523,6	143,6	498,5	156,8	472,2	171,6
	5	590,1	123,8	565,6	133,8	540,9	145,3	515,2	158,4	488,4	173,1
	6	610,1	125,9	584,1	135,7	558,6	147,0	532,4	160,0	505,0	174,7
	7	630,1	128,0	603,9	137,7	576,6	148,9	549,7	161,8	521,9	176,3
	8	650,6	130,2	623,9	139,8	595,9	150,9	567,5	163,6	539,0	178,0
165.2	9	671,6	132,4	644,2	141,9	615,8	152,9	585,9	165,5	556,6	179,8

Note: Nominal cooling capacity and power input are based on $\Delta T=5^{\circ}\text{C}$ entering/leaving condenser water temperature; evaporator fouling factor=0,0176 $\text{m}^2\text{ }^{\circ}\text{C}/\text{kW}$; condenser fouling factor=0,0440 $\text{m}^2\text{ }^{\circ}\text{C}/\text{kW}$.

Evaporator pressure drop ECOPLUS SE/XE 050.1 ÷ 165.2

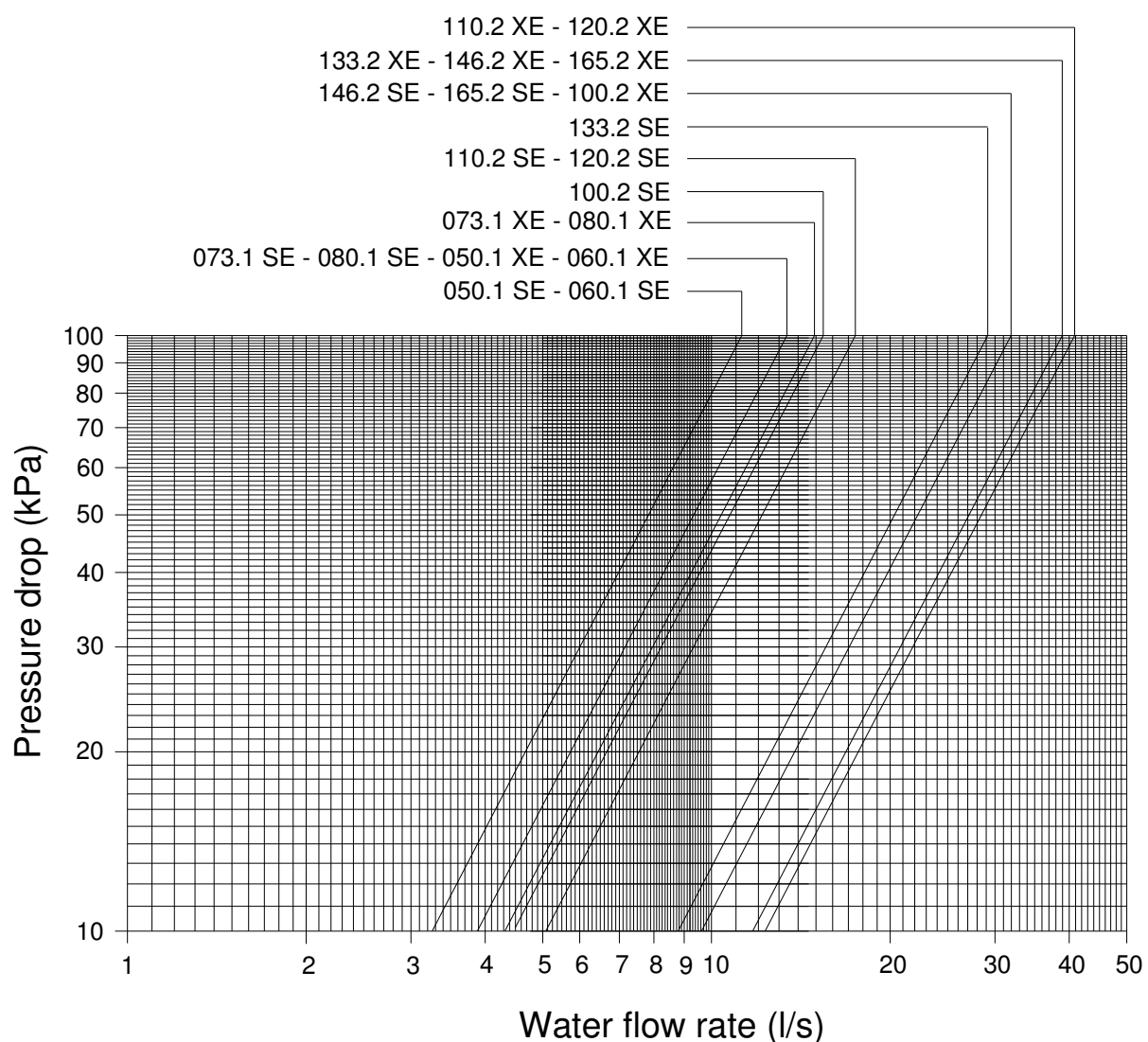

Condenser pressure drop ECOPLUS SE/XE 050.1 ÷ 165.2

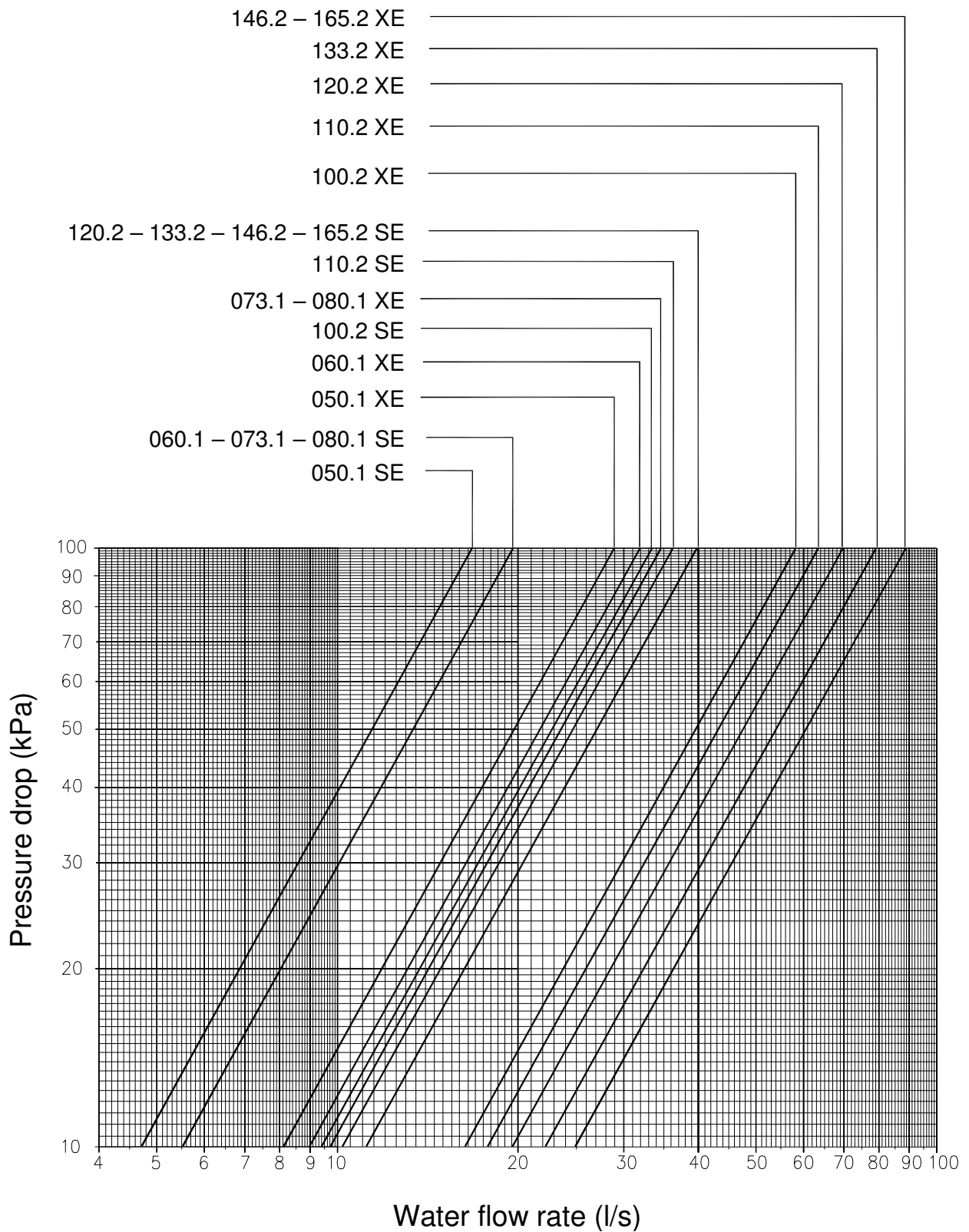

Partial heat recovery ratings ECOPLUS 050.1 ÷ 165.2

Unit	Leaving desuper-heaters water temperature °C	Entering condenser water temperature °C				
		30	35	40	45	50
		Heating capacity	Heating capacity	Heating capacity	Heating capacity	Heating capacity
		(kW)	(kW)	(kW)	(kW)	(kW)
050.1	45	21	22	23	24	25
	50	10	18	22	23	24
	55	6	11	17	20	21
060.1	45	22	29	30	31	32
	50	17	23	28	29	30
	55	10	16	24	26	27
073.1	45	35	36	37	38	39
	50	28	34	35	36	37
	55	19	30	31	32	33
080.1	45	48	43	44	45	46
	50	39	45	42	43	44
	55	28	44	38	38	39
100.2	45	42	44	46	48	50
	50	20	36	44	46	48
	55	12	22	34	40	42
110.2	45	43	51	53	55	57
	50	27	41	50	52	54
	55	16	27	41	46	48
120.2	45	44	58	60	62	64
	50	34	46	56	58	60
	55	20	32	48	52	54
133.2	45	57	65	67	69	71
	50	45	57	63	65	67
	55	29	46	55	58	60
146.2	45	70	72	74	76	78
	50	56	68	70	72	74
	55	38	60	62	64	66
165.2	45	96	86	88	90	92
	50	78	90	84	86	88
	55	56	88	76	76	78

Note: (1) Leaving evaporator water temperature 7°C - ΔT 5°C; ΔT condenser water temperature 5°C.

Heating capacity correction factors for different evaporator leaving water temp.

Evaporator leaving water temp.	9	8	7	6	5	4
Heating capacity correction factor	1,062	1,029	1,000	0,973	0,941	0,914

Partial heat recovery pressure drop ECOPLUS SE/XE 050.1 ÷ 165.2

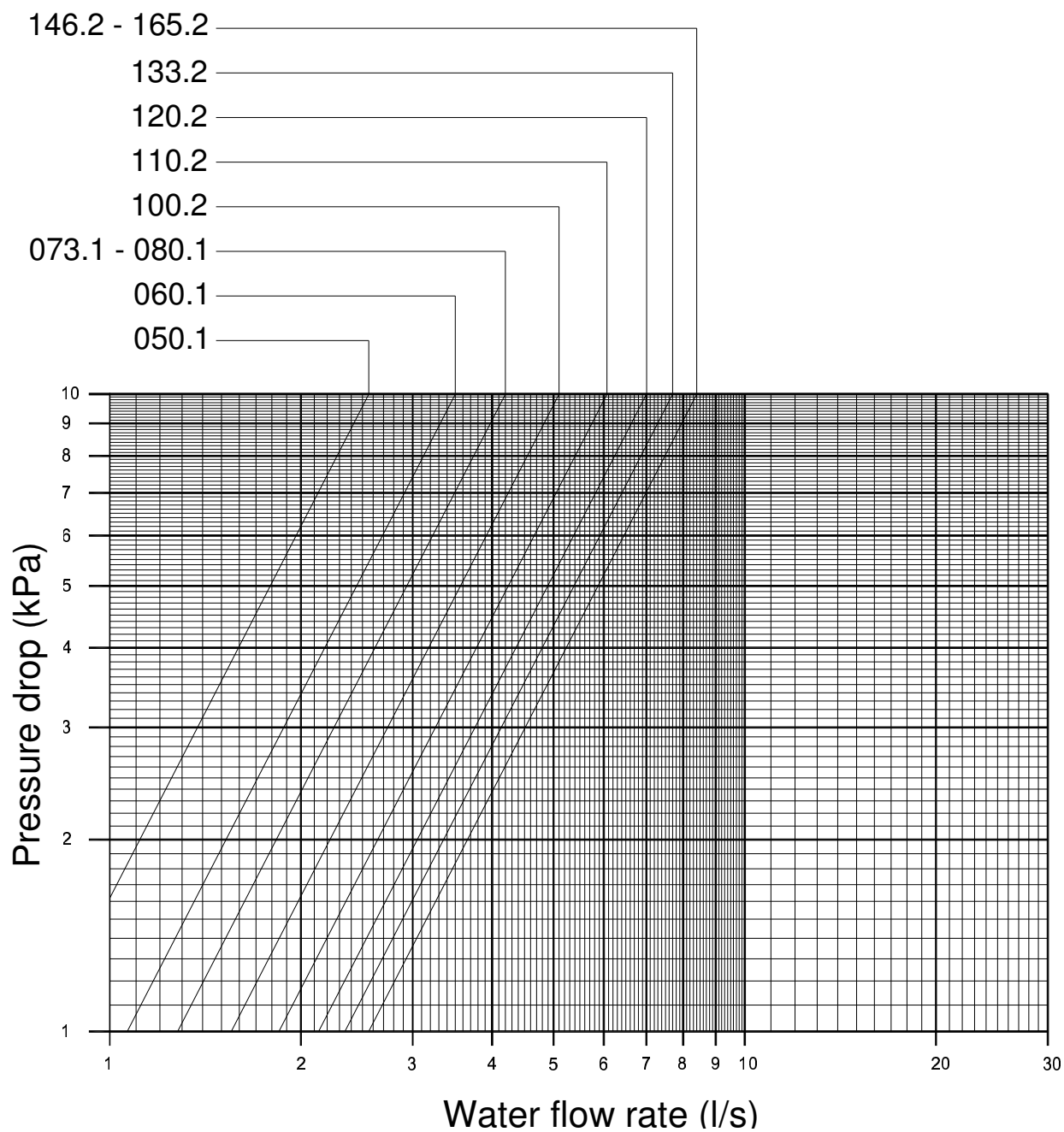

Total heat recovery ratings – ECOPLUS SE 050.1 ÷ 100.2

ECOPLUS Unit size	Evaporator Leaving Water Temperature (°C)	Heat recovery leaving water temperature - °C											
		35			40			45			50		
		Cooling Cap.ty [kW]	Power Input [kW]	Total Heat [kW]	Cooling Cap.ty [kW]	Power Input [kW]	Total Heat [kW]	Cooling Cap.ty [kW]	Power Input [kW]	Total Heat [kW]	Cooling Cap.ty [kW]	Power Input [kW]	Total Heat [kW]
050.1	4	151,6	37,5	189,1	145,2	42,3	187,5	138,6	47,5	186,1	131,7	53,1	184,8
	5	156,4	37,7	194,1	149,9	42,5	192,4	143,2	47,6	190,8	136,1	53,3	189,4
	6	161,4	37,8	199,2	154,7	42,6	197,3	147,8	47,8	195,6	140,7	53,5	194,2
	7	166,4	38,0	204,4	159,6	42,8	202,4	152,6	48,0	200,6	145,3	53,7	199,0
	8	171,5	38,1	209,6	164,6	43,0	207,6	157,4	48,2	205,6	150,0	53,9	203,9
	9	176,7	38,3	215,0	169,7	43,2	212,9	162,4	48,5	210,9	154,8	54,1	208,9
060.1	4	184,5	45,0	229,5	176,8	50,8	227,6	168,7	57,0	225,7	160,2	63,7	223,9
	5	190,4	45,2	235,6	182,5	51,0	233,5	174,3	57,2	231,5	165,6	64,0	229,6
	6	196,4	45,4	241,8	188,4	51,2	239,6	180,0	57,5	237,5	171,2	64,2	235,4
	7	202,5	45,6	248,1	194,3	51,4	245,7	185,8	57,7	243,5	176,8	64,5	241,3
	8	208,7	45,8	254,5	200,4	51,7	252,1	191,7	58,0	249,7	182,5	64,7	247,2
	9	215,0	46,0	261,0	206,5	51,9	258,4	197,7	58,2	255,9	188,3	65,0	253,3
073.1	4	234,2	55,9	290,1	224,2	63,0	287,2	213,7	70,6	284,3	202,7	78,8	281,5
	5	241,8	56,2	298,0	231,6	63,3	294,9	220,9	70,9	291,8	209,6	79,1	288,7
	6	249,6	56,5	306,1	239,1	63,6	302,7	228,2	71,3	299,5	216,7	79,5	296,2
	7	257,5	56,8	314,3	246,8	63,9	310,7	235,7	71,6	307,3	223,9	79,9	303,8
	8	265,5	57,0	322,5	254,6	64,3	318,9	243,3	72,0	315,3	231,3	80,3	311,6
	9	273,7	57,3	331,0	262,6	64,6	327,2	251,0	72,4	323,4	238,8	80,7	319,5
080.1	4	269,9	65,4	335,3	257,4	71,1	328,5	245,2	77,7	322,9	232,4	85,1	317,5
	5	279,0	66,3	345,3	266,3	72,0	338,3	253,3	78,5	331,8	240,3	85,9	326,2
	6	288,4	67,3	355,7	275,4	72,9	348,3	261,8	79,4	341,2	248,5	86,7	335,2
	7	297,9	68,3	366,2	284,6	73,9	358,5	270,8	80,3	351,1	256,6	87,5	344,1
	8	307,5	69,3	376,8	294,0	74,9	368,9	280,0	81,2	361,2	265,3	88,4	353,7
	9	317,3	70,3	387,6	303,7	75,9	379,6	289,2	82,2	371,4	274,2	89,3	363,5
100.2	4	305,9	75,1	381,0	292,9	84,7	377,6	279,5	95,0	374,5	265,5	106,2	371,7
	5	315,7	75,4	391,1	302,5	85,0	387,5	288,8	95,4	384,2	274,5	106,6	381,1
	6	325,7	75,7	401,4	312,2	85,4	397,6	298,2	95,8	394,0	283,7	107,1	390,8
	7	335,9	76,0	411,9	322,2	85,7	407,9	307,9	96,2	404,1	293,1	107,5	400,6
	8	346,3	76,3	422,6	332,3	86,1	418,4	317,7	96,6	414,3	302,6	107,9	410,5
	9	356,8	76,6	433,4	342,5	86,5	429,0	327,7	97,0	424,7	312,4	108,4	420,8

Note: Values are based on $\Delta T=5^{\circ}\text{C}$ entering/leaving condenser water temperature; $\Delta T=5^{\circ}\text{C}$ entering/leaving evaporator water temperature and with evaporator fouling factor=0,0176 $\text{m}^2 \text{ }^{\circ}\text{C}/\text{kW}$, condenser fouling factor=0,0440 $\text{m}^2 \text{ }^{\circ}\text{C}/\text{kW}$.

Total heat recovery ratings – ECOPLUS SE 110.2 ÷ 165.2

ECOPLUS Unit size	Evaporator Leaving Water Temperature (°C)	Heat recovery leaving water temperature - °C											
		35			40			45			50		
		Cooling Cap.ty [kW]	Power Input [kW]	Total Heat [kW]	Cooling Cap.ty [kW]	Power Input [kW]	Total Heat [kW]	Cooling Cap.ty [kW]	Power Input [kW]	Total Heat [kW]	Cooling Cap.ty [kW]	Power Input [kW]	Total Heat [kW]
110.2	4	341,2	82,7	423,9	326,7	93,2	419,9	311,7	104,6	416,3	295,9	117,0	412,9
	5	352,2	83,1	435,3	337,5	93,6	431,1	322,1	105,1	427,2	306,0	117,4	423,4
	6	363,4	83,4	446,8	348,4	94,1	442,5	332,7	105,5	438,2	316,3	117,9	434,2
	7	374,8	83,8	458,6	359,5	94,5	454,0	343,5	106,0	449,5	326,8	118,4	445,2
	8	386,5	84,1	470,6	370,8	94,9	465,7	354,5	106,4	460,9	337,5	118,9	456,4
	9	398,3	84,4	482,7	382,3	95,3	477,6	365,7	106,9	472,6	348,4	119,4	467,8
120.2	4	369,2	90,1	459,3	353,8	101,6	455,4	337,6	114,0	451,6	320,6	127,5	448,1
	5	381,0	90,5	471,5	365,2	102,0	467,2	348,8	114,5	463,3	331,4	127,9	459,3
	6	393,0	90,8	483,8	376,9	102,4	479,3	360,2	115,0	475,2	342,5	128,4	470,9
	7	405,2	91,2	496,4	388,8	102,9	491,7	371,7	115,4	487,1	353,7	129,0	482,7
	8	417,6	91,6	509,2	400,9	103,3	504,2	383,5	115,9	499,4	365,2	129,5	494,7
	9	430,2	92,0	522,2	413,2	103,8	517,0	395,5	116,4	511,9	376,9	130,0	506,9
133.2	4	413,3	100,7	514,0	395,9	113,5	509,4	377,8	127,3	505,1	358,6	142,3	500,9
	5	426,5	101,2	527,7	408,8	114,0	522,8	390,3	127,9	518,2	370,8	142,9	513,7
	6	439,9	101,7	541,6	421,9	114,6	536,5	403,0	128,5	531,5	383,1	143,5	526,6
	7	453,6	102,1	555,7	435,2	115,1	550,3	416,0	129,0	545,0	395,7	144,1	539,8
	8	467,5	102,6	570,1	448,8	115,6	564,4	429,2	129,6	558,8	408,5	144,7	553,2
	9	481,7	103,0	584,7	462,6	116,2	578,8	442,6	130,2	572,8	421,6	145,4	567,0
146.2	4	457,3	111,4	568,7	438,0	125,5	563,5	417,9	140,7	558,6	396,7	157,2	553,9
	5	471,9	112,0	583,9	452,3	126,1	578,4	431,7	141,4	573,1	410,1	157,8	567,9
	6	486,8	112,5	599,3	466,8	126,7	593,5	445,8	142,0	587,8	423,8	158,5	582,3
	7	502,0	113,1	615,1	481,5	127,4	608,9	460,2	142,7	602,9	437,7	159,2	596,9
	8	517,4	113,6	631,0	496,5	128,0	624,5	474,8	143,4	618,2	451,8	160,0	611,8
	9	533,0	114,2	647,2	511,8	128,6	640,4	489,6	144,1	633,7	466,2	160,7	626,9
165.2	4	529,5	129,8	659,3	505,4	141,4	646,8	480,5	154,5	635,0	454,2	169,3	623,5
	5	547,0	131,5	678,5	522,6	143,0	665,6	497,0	156,1	653,1	470,4	170,8	641,2
	6	564,9	133,3	698,2	540,1	144,8	684,9	514,0	157,8	671,8	486,8	172,4	659,2
	7	583,2	135,2	718,4	557,9	146,6	704,5	531,3	159,5	690,8	503,5	174,0	677,5
	8	601,8	137,2	739,0	576,0	148,4	724,4	548,9	161,3	710,2	520,6	175,7	696,3
	9	621,2	139,2	760,4	594,4	150,4	744,8	566,8	163,1	729,9	538,0	177,5	715,5

Note: Values are based on $\Delta T=5^{\circ}\text{C}$ entering/leaving condenser water temperature; $\Delta T=5^{\circ}\text{C}$ entering/leaving evaporator water temperature and with evaporator fouling factor=0,0176 m² °C/kW, condenser fouling factor=0,0440 m² °C/kW.

Total heat recovery ratings – ECOPLUS XE 050.1 ÷ 100.2

ECOPLUS Unit size	Evaporator Leaving Water Temperature (°C)	Heat recovery leaving water temperature - °C											
		35			40			45			50		
		Cooling Cap.ty [kW]	Power Input [kW]	Total Heat [kW]	Cooling Cap.ty [kW]	Power Input [kW]	Total Heat [kW]	Cooling Cap.ty [kW]	Power Input [kW]	Total Heat [kW]	Cooling Cap.ty [kW]	Power Input [kW]	Total Heat [kW]
050.1	4	167,1	37,1	204,2	159,6	41,9	201,5	151,9	47,0	198,9	143,9	52,6	196,5
	5	172,9	37,2	210,1	165,2	42,0	207,2	157,3	47,2	204,5	149,2	52,8	202,0
	6	178,8	37,3	216,1	171,0	42,2	213,2	162,9	47,4	210,3	154,6	53,0	207,6
	7	184,8	37,4	222,2	176,8	42,3	219,1	168,6	47,5	216,1	160,1	53,1	213,2
	8	191,0	37,5	228,5	182,8	42,5	225,3	174,4	47,7	222,1	165,7	53,3	219,0
	9	197,3	37,6	234,9	189,0	42,6	231,6	180,4	47,9	228,3	171,5	53,5	225,0
060.1	4	200,8	44,6	245,4	192,0	50,4	242,4	182,8	56,6	239,4	173,2	63,2	236,4
	5	207,7	44,8	252,5	198,7	50,6	249,3	189,3	56,8	246,1	179,5	63,4	242,9
	6	214,7	44,9	259,6	205,5	50,7	256,2	195,9	57,0	252,9	185,9	63,7	249,6
	7	221,8	45,1	266,9	212,4	50,9	263,3	202,6	57,2	259,8	192,4	63,9	256,3
	8	229,1	45,2	274,3	219,5	51,1	270,6	209,5	57,4	266,9	199,1	64,1	263,2
	9	236,6	45,3	281,9	226,7	51,3	278,0	216,5	57,6	274,1	205,8	64,4	270,2
073.1	4	248,9	54,7	303,6	237,9	61,7	299,6	226,6	69,3	295,9	214,7	77,4	292,1
	5	257,4	54,9	312,3	246,2	62,0	308,2	234,6	69,5	304,1	222,4	77,7	300,1
	6	266,1	55,1	321,2	254,7	62,2	316,9	242,8	69,8	312,6	230,3	78,0	308,3
	7	275,0	55,3	330,3	263,3	62,5	325,8	251,2	70,1	321,3	238,4	78,3	316,7
	8	284,1	55,5	339,6	272,1	62,7	334,8	259,7	70,4	330,1	246,7	78,6	325,3
	9	293,4	55,7	349,1	281,1	63,0	344,1	268,4	70,7	339,1	255,1	78,9	334,0
080.1	4	287,4	64,6	352,0	274,8	70,1	344,9	261,8	76,3	338,1	248,1	83,4	331,5
	5	296,9	65,5	362,4	284,1	71,0	355,1	270,8	77,1	347,9	256,9	84,1	341,0
	6	306,6	66,5	373,1	293,6	71,8	365,4	280,0	78,0	358,0	265,8	84,9	350,7
	7	316,6	67,5	384,1	303,3	72,8	376,1	289,4	78,8	368,2	275,0	85,7	360,7
	8	326,7	68,5	395,2	313,1	73,7	386,8	299,0	79,7	378,7	284,2	86,6	370,8
	9	337,1	69,5	406,6	323,1	74,7	397,8	308,8	80,7	389,5	293,7	87,5	381,2
100.2	4	328,4	74,1	402,5	314,0	83,7	397,7	299,0	93,9	392,9	283,5	105,1	388,6
	5	339,6	74,3	413,9	324,8	83,9	408,7	309,5	94,3	403,8	293,7	105,4	399,1
	6	351,1	74,5	425,6	336,0	84,2	420,2	320,3	94,6	414,9	304,2	105,7	409,9
	7	362,8	74,7	437,5	347,3	84,5	431,8	331,3	94,9	426,2	314,9	106,1	421,0
	8	374,7	74,9	449,6	358,9	84,8	443,7	342,6	95,2	437,8	325,8	106,5	432,3
	9	386,9	75,1	462,0	370,8	85,0	455,8	354,1	95,6	449,7	336,9	106,8	443,7

Note: Values are based on $\Delta T=5^{\circ}\text{C}$ entering/leaving condenser water temperature; $\Delta T=5^{\circ}\text{C}$ entering/leaving evaporator water temperature and with evaporator fouling factor=0,0176 m² °C/kW, condenser fouling factor=0,0440 m² °C/kW.

Total heat recovery ratings – ECOPLUS XE 110.2 ÷ 165.2

ECOPLUS Unit size	Evaporator Leaving Water Temperature (°C)	Heat recovery leaving water temperature - °C											
		35			40			45			50		
		Cooling Cap.ty [kW]	Power Input [kW]	Total Heat [kW]	Cooling Cap.ty [kW]	Power Input [kW]	Total Heat [kW]	Cooling Cap.ty [kW]	Power Input [kW]	Total Heat [kW]	Cooling Cap.ty [kW]	Power Input [kW]	Total Heat [kW]
110.2	4	366,0	81,5	447,5	349,9	92,0	441,9	333,2	103,4	436,6	315,8	115,6	431,4
	5	378,6	81,8	460,4	362,1	92,3	454,4	345,0	103,7	448,7	327,2	115,9	443,1
	6	391,4	82,0	473,4	374,5	92,7	467,2	357,1	104,1	461,2	338,9	116,3	455,2
	7	404,4	82,2	486,6	387,2	93,0	480,2	369,4	104,4	473,8	350,8	116,7	467,5
	8	417,8	82,5	500,3	400,2	93,3	493,5	381,9	104,8	486,7	363,0	117,1	480,1
	9	431,4	82,7	514,1	413,4	93,6	507,0	394,8	105,2	500,0	375,5	117,6	493,1
120.2	4	398,0	88,8	486,8	380,7	100,3	481,0	362,7	112,6	475,3	343,8	125,9	469,7
	5	411,5	89,1	500,6	393,8	100,6	494,4	375,5	113,0	488,5	356,2	126,3	482,5
	6	425,3	89,4	514,7	407,2	101,0	508,2	388,5	113,4	501,9	368,8	126,8	495,6
	7	439,4	89,6	529,0	420,9	101,3	522,2	401,7	113,8	515,5	381,7	127,2	508,9
	8	453,7	89,8	543,5	434,8	101,6	536,4	415,2	114,2	529,4	394,8	127,6	522,4
	9	468,3	90,1	558,4	449,0	101,9	550,9	429,1	114,6	543,7	408,2	128,1	536,3
133.2	4	444,8	98,1	542,9	425,5	110,8	536,3	405,5	124,4	529,9	384,6	139,1	523,7
	5	459,9	98,4	558,3	440,2	111,2	551,4	419,8	124,8	544,6	398,4	139,6	538,0
	6	475,3	98,7	574,0	455,2	111,5	566,7	434,3	125,3	559,6	412,5	140,0	552,5
	7	491,0	99,0	590,0	470,4	111,9	582,3	449,1	125,7	574,8	426,8	140,5	567,3
	8	507,0	99,2	606,2	486,0	112,2	598,2	464,3	126,1	590,4	441,5	141,0	582,5
	9	523,4	99,5	622,9	501,9	112,6	614,5	479,7	126,6	606,3	456,5	141,5	598,0
146.2	4	484,8	107,3	592,1	464,1	121,1	585,2	442,7	136,1	578,8	420,2	152,2	572,4
	5	501,0	107,6	608,6	479,9	121,5	601,4	458,0	136,5	594,5	435,1	152,6	587,7
	6	517,6	107,9	625,5	496,1	121,9	618,0	473,7	137,0	610,7	450,3	153,1	603,4
	7	534,5	108,2	642,7	512,5	122,3	634,8	489,7	137,4	627,1	465,8	153,6	619,4
	8	551,7	108,5	660,2	529,3	122,7	652,0	506,0	137,9	643,9	481,6	154,1	635,7
	9	569,3	108,8	678,1	546,4	123,1	669,5	522,7	138,3	661,0	497,7	154,6	652,3
165.2	4	561,0	126,1	687,1	537,3	137,0	674,3	512,4	149,4	661,8	486,4	163,4	649,8
	5	580,0	127,8	707,8	555,2	138,5	693,7	529,9	150,8	680,7	503,4	164,8	668,2
	6	600,3	129,6	729,9	573,6	140,1	713,7	547,7	152,3	700,0	520,7	166,2	686,9
	7	621,0	131,5	752,5	593,6	141,9	735,5	565,9	153,9	719,8	538,4	167,6	706,0
	8	641,8	133,5	775,3	614,2	143,8	758,0	585,1	155,6	740,7	556,4	169,1	725,5
	9	663,0	135,5	798,5	634,9	145,7	780,6	605,5	157,4	762,9	574,7	170,7	745,4

Note: Values are based on $\Delta T=5^{\circ}\text{C}$ entering/leaving condenser water temperature; $\Delta T=5^{\circ}\text{C}$ entering/leaving evaporator water temperature and with evaporator fouling factor=0,0176 $\text{m}^2 \text{ }^{\circ}\text{C}/\text{kW}$, condenser fouling factor=0,0440 $\text{m}^2 \text{ }^{\circ}\text{C}/\text{kW}$.

Total heat recovery pressure drop ECOPLUS SE/XE 050.1 ÷ 165.2

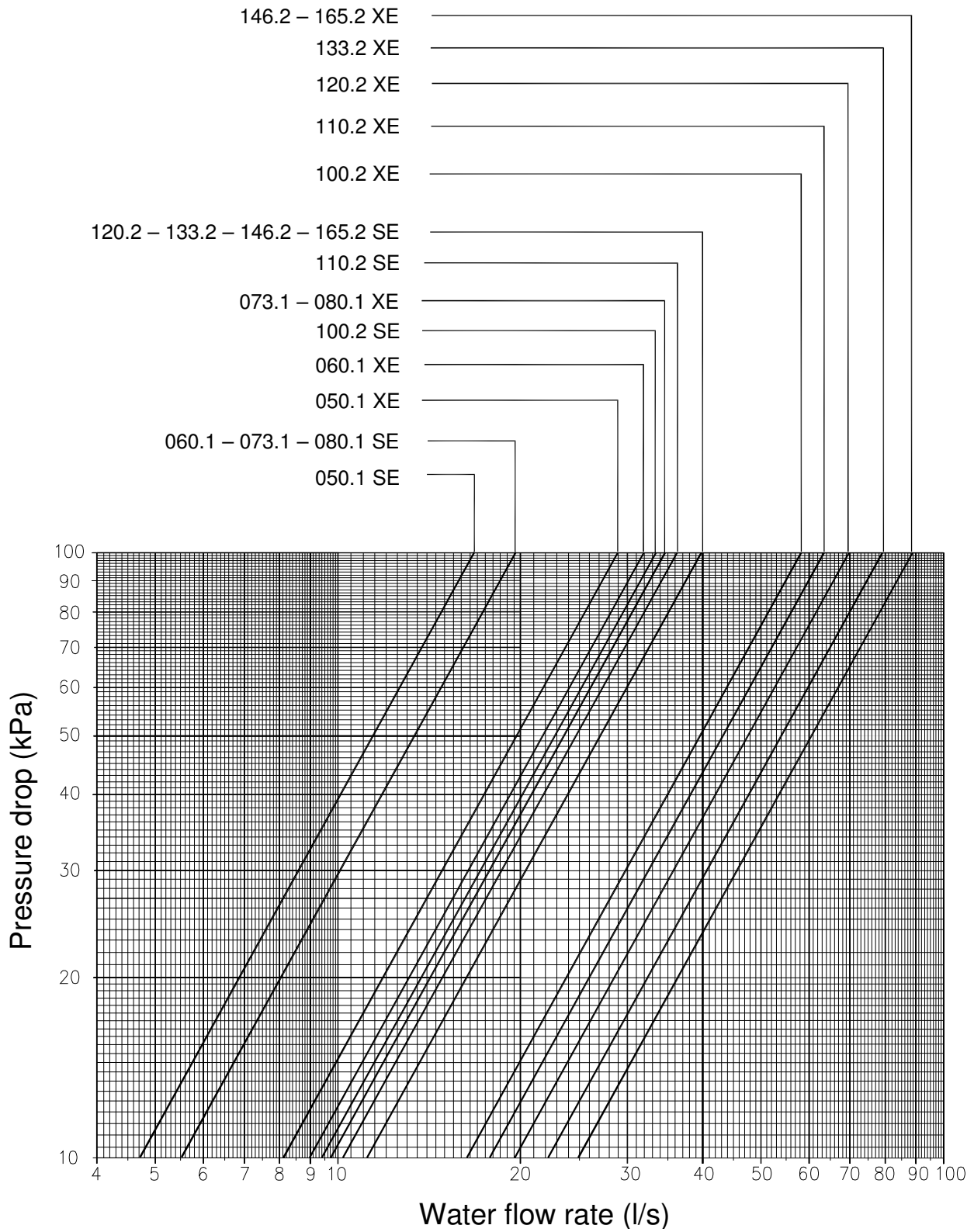

Dimensions ECOPLUS 050.1 ÷ 080.1

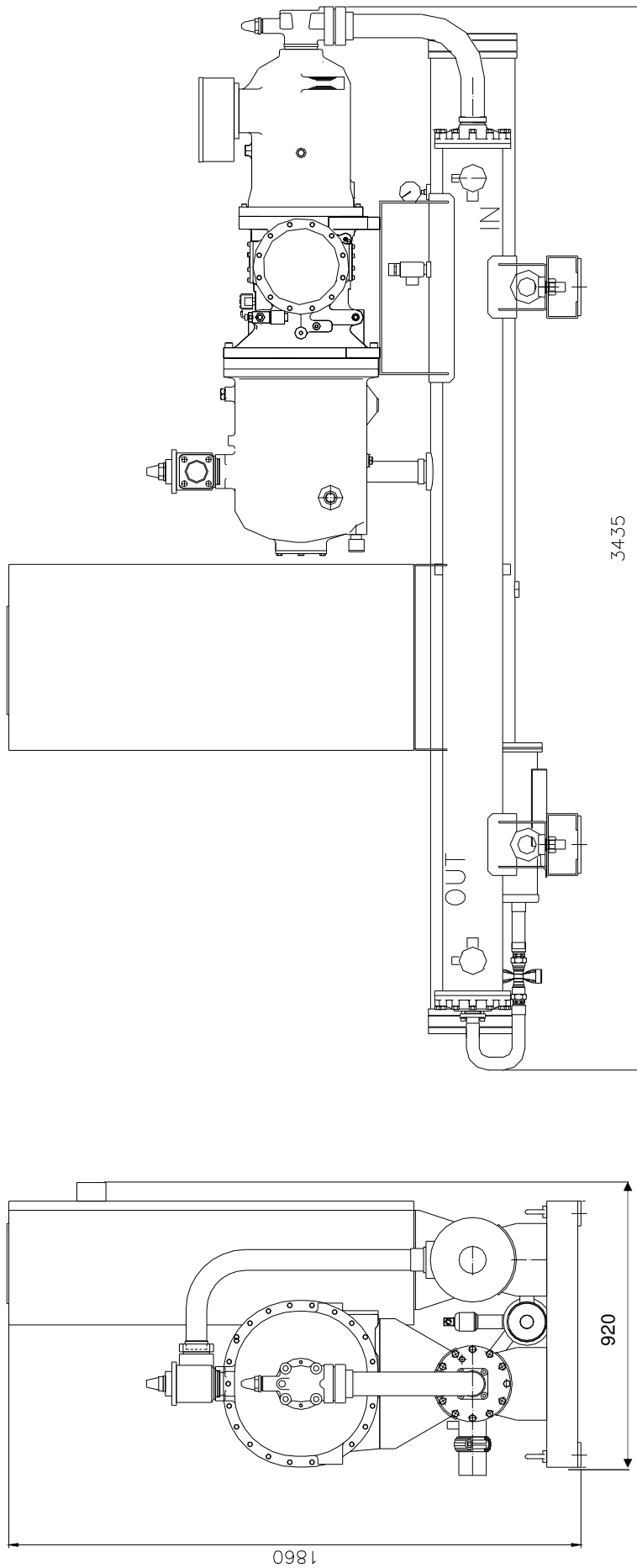

Dimensions ECOPLUS 100.2 ÷ 165.2

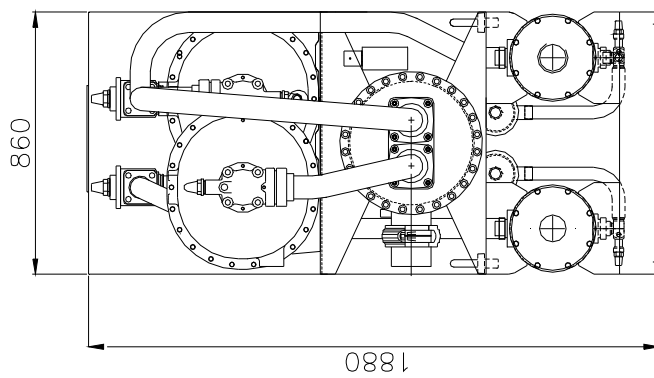
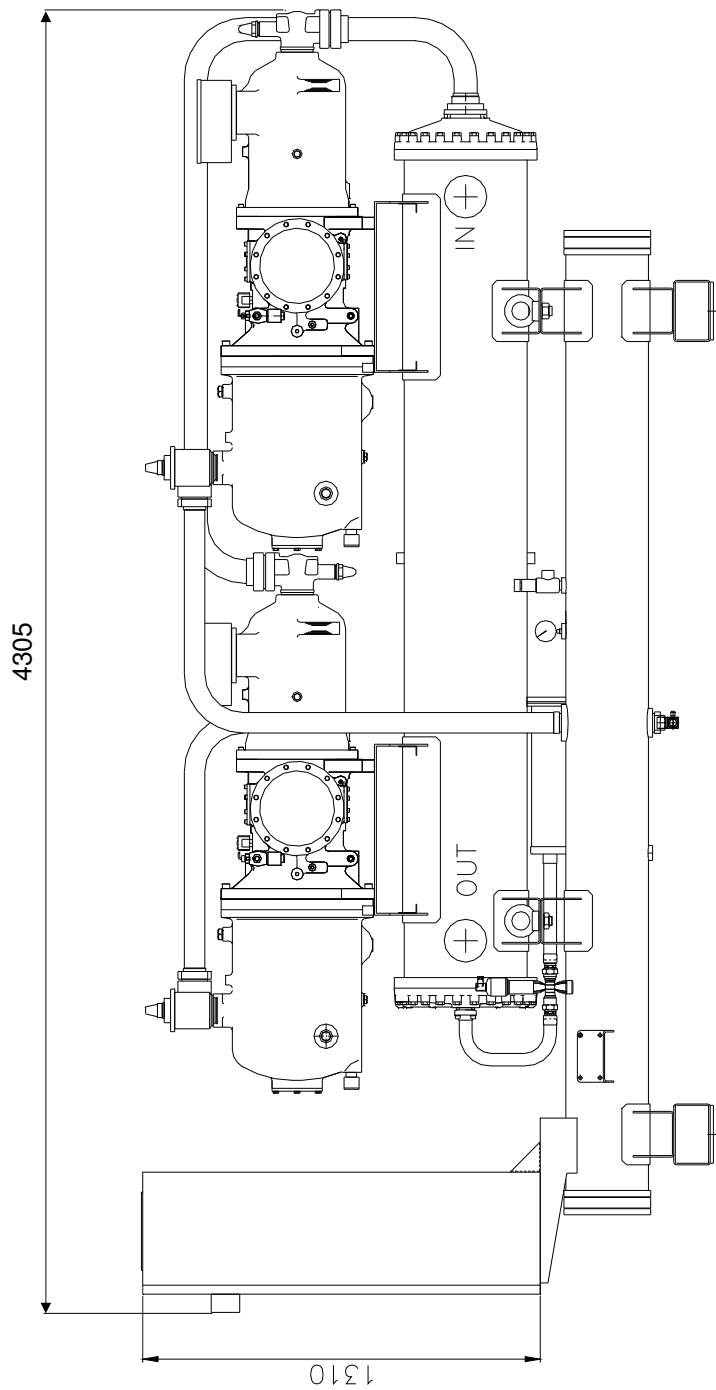

Technical Specification Water Cooled Screw Chiller – ECOPLUS 050.1÷165.2

To supply and install, where specified in the project n° unit(s) water cooled chiller with cooling capacity of kW, to cool l/sec. of water from °C to °C, condenser entering water temperature °C, condenser leaving water temperature °C.

The unit should work with electricity at V, 3ph, 50Hz. The electrical power absorbed should not exceed kW. The units COP will be at least at the working conditions of the project. Part load COP will be at least at the working conditions of the project.

The units will have 1 or 2 independent refrigerant circuits, and the respective electronic microprocessor will allow the starting of the compressors. Each chiller will be factory assembled and protected by an epoxy paint.

The unit will be tested at full load in the factory at the nominal working conditions and water temperatures. Before shipment a full test will be held to avoid any losses. Chiller will be delivered to the job site completely assembled and charged with refrigerant and oil.

Comply with the manufacturer instructions for rigging and handling equipment.

GENERAL

All units should be designed and manufactured in accordance with applicable selections of the following which are equivalent to American Air-conditioning industry applicable codes:

Rating of chillers	EN 12055
Construction of pressure vessel	TUV Standards (on request)
Electrical codes	IEC 204-1 CEI 44-5 Elect. & Safety Codes
Safety Codes	CEI-EN 60204-1 Codes
Manufacturing Quality Stds	ISO 9001:2000

REFRIGERANT

Will be accepted only HFC 134a.

UNIT DESCRIPTION

Each chiller consist of single or multiple semi-hermetic rotary screw compressor, direct expansion avaporator, water cooled condenser section, control system and all components necessary for safe and controlled unit operation.

NOISE LEVEL AND VIBRATIONS

Sound pressure level at 1 meter distance in free field, semispheric conditions, shall not exceeddBA. The sound pressure levels must be rated in accordance to ISO 3744. Other types of rating unacceptable. Vibration level should not exceed 2 mm/s.

DIMENSIONS

Unit length shall not exceed mm, unit width shall not exceed mm, unit height shall not exceed mm.

CHILLER COMPONENTS

Compressors

- ✓ The compressors shall be field serviceable, semi-hermetic, single-screw type with one main helical rotor meshing with two opposed gaterotor. Twin-screw compressor will no accepted because of the large bearing loads inherent with this design. For a Single-screw compressor the two exactly opposed gaterotors create two exactly opposed compression cycles which results in balanced forces acting on the rotor compressor. The gaterotors will be constructed of a carbon impregnated engineered composite material. The gaterotor supports will be constructed of cast iron.
- ✓ The oil injection shall be used for these compressors in order to get high COP also at high condensing pressure and low sound pressure levels in each load condition.
- ✓ Refrigerant system differential pressure shall provide oil flow throught service replaceble, 0.5 micron, full flow, cartridge type oil filter internal to compressor. Filter bypass or oil pump not acceptable.
- ✓ The compressor's oil cooling must be realized by liquid injection. External dedicated heat exchanger and additional piping to carry the oil from the compressor to heat exchanger and viceversa will be not accepted.
- ✓ The compressor shall be provided with a integrated high efficiency, oil separator and with built-in oil filter. The oil separator shall be provided with two sight-glasses, one each side, to check the level of oil in the reservoir at the bottom of the separator.
- ✓ The compressor shall be direct electrical drive, without gear transmission between the screw and the electrical motor. The motor's compressor shall be designed for star/delta. Soft start should be available as option.
- ✓ The compressor casing shall be provided with ports to realize economized refrigerant cycles.
- ✓ Shall be present two thermal protection realized by a thermistor for high temperature protection to motor and a thermistor for discharge gas high temperature protection.
- ✓ The compressor shall be provided with an automatic spring return of capacity control valve to the minimum load position to ensure compressor starting always at minimum motor load so with the minimum mechanical stress.
- ✓ The compressor discharge connection shall be fitted with a check valve and with a stop valve.
- ✓ The compressor discharge shall be fitted with a head pressure control valve.

Evaporator

- ✓ The units shall be supplied with shell and tubes counter-flow evaporator single refrigerant pass. It will be direct expansion with refrigerant inside the tubes and water outside (shell side) with carbon steel tube sheets, with straight copper tubes that are spirally wound internally for higher efficiencies, expanded on the tube plates.
- ✓ The external shell, shall be linked with an electrical heater to prevent freezing up to -28 C ambient temperature, commanded by a thermostat and shall be insulated with flexible, closed cell polyurethane insulation material.
- ✓ The evaporator will have 1 or 2 circuits, one for each compressor and shall be single refrigerant pass to ensure a simplier oil circulation so to ensure always a perfect oil return to the compressor.
- ✓ Evaporator is manufactured in accordance to PED approval.

Condensers

- ✓ Condensers will be shell and cleanable, through-tube type.
- ✓ The unit will have one condensers per circuit.
- ✓ Each condenser shall have a carbon steel and seamless, integrally finned high efficiency copper tubes, roll expanded into heavy carbon steel tube sheets.
- ✓ Water heads shall be removable and include vent and drain plugs.
- ✓ Condensers will come complete with liquid shut-off valve, spring loaded relief valve.

Refrigerant circuit

- ✓ The unit must have refrigerant circuits completely independent of each other with one compressor per circuit.
- ✓ Each circuit shall include: electronic expansion valve, external high efficiency oil separator, compressor discharge shut-off valve, a liquid line shut-off valve with charging connection, replaceable core filter-drier, sight glass with moisture indicator and insulated suction line. Suction line shut-off valve should be available as option.

Regulation of cooling capacity

- ✓ Each unit will have a microprocessor for the control of compressor slide valve's position (2 slide valves, one for each compressor's cycles).
- ✓ The slides shall have a stepless motion that allows a unit's operation with infinitely variable capacity control down to 25% (1 compressor) or down to 12,5% (2 compressors) of the cooling capacity. The chiller shall be capable of stable operation to a minimum of 25% (1 compressor) or to a minimum of 12,5% (2 compressors) of full load without hot gas bypass.
- ✓ Step unloading unacceptable because of evaporator leaving water temperature fluctuation and low compressor's efficiency at partial load.
- ✓ The system shall stage the unit based on the leaving water temperature.

Electronic expansion valve

- ✓ Electronic expansion valve allows a simple and perfect control system that quickly interacts at load variations. This valve combines two functions: liquid solenoid and electronic expansion valve.
- ✓ It is managed directly by a microprocessor to match exactly the plant thermal load.
- ✓ Thermostatic valve unacceptable because of:
 - its limited load range;
 - higher refrigerant pressure drop;
 - because of leaving evaporator water temperature control less good than an electronic device;
 - thermal expansion device needs a higher differential pressure between high pressure side and low pressure side to work correctly. This doesn't allow to work with low condensing pressure and therefore doesn't allow to reach the money saving that is possible to have with these chiller working conditions.

Control panel

- ✓ Field power connections, control interlock terminals, and unit control system should be centrally located in an electric panel (IP 43).
- ✓ The Power components and control equipment shall be separately mounted in different compartments of the control panel.
- ✓ The Compressor starting method will be star/delta, with an option for Softstart.
- ✓ Power and starting controls should include fuses and contactors for the compressor and fan motor windings.
- ✓ Operating and safety controls should include energy saving; emergency stop switch; thermal overload protection for each compressor motor; high and low pressure cut-out switch (for each refrigerant circuit); anti-freeze thermostat; cut-out switch for each compressor.
- ✓ All of the information regarding the unit shall be shown on a display with a built-in calendar and clock that will provide unit scheduling throughout the year.
- ✓ The following features and functions shall be included:
 - resetting chilled water temperature by controlling the return water temperature or by a remote 4-20 mA DC signal;
 - soft load function to prevent the system from operating at full load during the chilled fluid pulldown period;
 - password protection of critical parameters of control;
 - start-to-start and stop-to-start timers to provide minimum compressor off-time with maximum motor protection;
 - communication capability with a PC or remote monitoring;
 - lead-lag selection by manual or automatically by circuit run hours;
 - double set point for brine unit version;
 - scheduling via internal time clock to allow programming of a yearly start-stop schedule accommodating weekends and holidays.

Display Capabilities

The controller as a minimum shall be capable of monitoring and displaying the following data:

Operating Conditions

Ent./ Lvg. Evaporator fluid Temp.
Ent.ering Condenser fluid Temp.
Operating Chilled Fluid Setpoint
Oil / Discharge gas Press. (per comp.)
Condensing Press. (per comp.)
Evaporator Press. (per comp.)
Unit Enabled
Compressor Enabled
Water Setpoint Reset
Demand Limit or Current Limit
(Site Selectable)

Alarms

Phase Monitor
Freeze Protection
Evaporator Flow
Low Gas Pressure (per comp.)
Transition Fault, (per comp.)
Oil Diff. press. (per comp.)
Low Oil Pressure (per comp.)
High Gas Pressure Trip (per comp.)
Motor Overload, (per comp.)
Transducer faults
Units Off-Line
External fault
Processor Faults
Maintenance requirements

Standard Customer Interfaces

The controller as a minimum shall be capable of providing the following interlocks: -

Chiller Enable Signal: Digital Input,
customer contact must be capable of handling 24Volts, 50HZ, 1 Amp.

Chiller Common Fault: Volt free, normally open, digital contact,
Must be capable of switching 250 V, 50 HZ, 10 Amp.

Pump Enable Signal: Volt free, normally open, digital contact,
Must be capable of switching 250 V, 50 HZ, 10 Amp.

Setpoint Override: 4 – 20 mA DC analogue input signal.

Demand Limit: 4 – 20 mA DC analogue input signal.

or

Current Limit: 4 – 20 mA DC analogue input signal.

Optional Customer Interfaces

Compressor Running Signals: Volt free, normally open, digital contact,
Capable of switching 250 V, 50 HZ, 10 Amp.

Optional High Level Communications Interface

Using ModBus, Lonworks or Bacnet protocols

We reserve the right to make changes in design and construction at any time without notice, thus the cover picture is not binding.

McQuay partecipa al programma di
Certificazione Eurovent.
I prodotti interessati figurano nella Guida
Eurovent dei Prodotti Certificati.



McQuay is participating in the Eurovent
Certification Programme
Product are as listed in the Eurovent
Directory of Certified Products

McQuay[®]
International

McQuay Italia S.P.A.

S.S. Nettunense, km 12+300 – 00040 Cecchina (Roma) Italia – Tel. (06) 937311 – Fax (06) 9374014 – E-mail: info@mcquayeuropa.com
www.mcquayeuropa.com